

TABLE OF CONTENTS

	Page
SAFETY SUMMARY	2
HOW TO USE THIS MANUAL	7
GENERAL INFORMATION	8
EQUIPMENT DESCRIPTION	12
SECTION I OPERATING INSTRUCTIONS	19
SECTION II MOUNTING PROCEDURES	32
SECTION III ZEROING PROCEDURES	35
SECTION I USER PREVENTIVE MAINTENANCE CHECKS	39
SECTION II TROUBLESHOOTING	44
SECTION III MAINTENANCE	47
SERVICE/PACKING AND UNPACKING	52
APPENDIX A REPAIR PARTS	54

SAFETY SUMMARY

WARNING

**INVISIBLE LASER RADIATION
AVOID DIRECT EXPOSURE TO THE BEAM**

**VISIBLE RED POINTER (CLASS IIIa)
LASER WAVELENGTH: 635 nm
OUTPUT: <5 mW**

**INFRARED LASER POINTER / CLASS I / EYE-SAFE
LASER WAVELENGTH: 850 nm
OUTPUT: <0.7 mW**

- DO NOT stare into the laser beam.
- DO NOT look into the laser beam through binoculars or telescopes.
- DO NOT point the laser beam at mirror-like surfaces.
- DO NOT shine the laser beam into other individual's eyes.



Safety Data

LASER	Power Output	SAFETY CLASS	NOHD (m)
RED Visible Laser - Low Power	<1 mW	IIIa	32.7
RED Visible Laser - High Power	<5 mW		79.2
IR LASER - Low Power	<0.7 mW	I	22.7
IR LASER - High Power	<0.7 mW		56.8

WARNING

Identifies a clear danger to the person doing that procedure.

CAUTION

Identifies risk of damage to the equipment.

NOTE

Used to highlight essential procedures, conditions, statements, or convey important instructional data to the user.

WARNING

Be sure the weapon is CLEAR and on SAFE before proceeding.

WARNING

RISK OF DETECTION BY ENEMY

To reduce the risk of detection by an enemy using a Night Vision Device (NVD), avoid prolonged activation of the CQBL-1.

WARNING

The infrared beam is more detectable to an enemy using a NVD when used in smoke, fog and rain. Avoid prolonged activation of the CQBL-1 in these conditions.

WARNING

REMOVE THE BATTERIES AFTER EACH USE. DO NOT store with the battery installed.

WARNING

Make sure the Mode Selector Switch is in the OFF position and the battery is removed before inspecting the Exit Port Lenses of the CQBL-1.

WARNING

All directions, such as CW and CCW, are given from the shooter's point of view, as though the CQBL-1 were weapon mounted.

WARNING

If the Mode Selector Switch is not in the OFF position, the laser can be inadvertently activated by depressing the fire button on the top of the housing.

WARNING

If a laser borelight is used to boresight the laser,
be sure to remove the borelight from the weapon prior to firing.

WARNING

The CQBL-1 is powered by one 3V CR123A Lithium Manganese Dioxide (Li/MnO₂) battery. The following safety precautions apply when handling lithium batteries:

- DO NOT short circuit, puncture, or disassemble
- DO NOT attempt to recharge
- NEVER dispose of lithium batteries in a fire, or in any way expose lithium batteries to excessive heat
- Batteries may explode if disassembled, crushed, recharged, or exposed to high temperatures
- Avoid mechanical or electrical abuse
- Prior to use, inspect all batteries for cracks, leakage, or bulging
- NEVER install a defective battery in the CQBL-1
- DO NOT install incorrectly
- Store lithium batteries at room temperature
- Refer to applicable federal, state, and local laws and regulations for proper disposal of the 3V CR123A Lithium Batteries

CAUTION

DO NOT over-adjust the laser adjusters by forcing them beyond their end of travel.

CAUTION

Use ONLY water, mild detergent, alcohol, or approved lens cleaning solution on the CQBL-1or permanent damage may occur. The use of gun cleaning agents that contain percholoroethylene or methylene chloride may permanently damage CQBL-1.

CAUTION

DO NOT remove the Remote Cable Switch by pulling on the cable.

HOW TO USE THIS MANUAL

Usage

You must familiarize yourself with the entire manual before operating the equipment. Read the complete maintenance task before performing maintenance and follow all **WARNINGS, CAUTIONS** and **NOTES**.

Manual Overview

The manual contains sections for Operating and Maintaining the CQBL-1 and laser safety.

Appendix A Repair Parts

CHAPTER 1—GENERAL INFORMATION



Figure 1-1 QBL-1 in Use

1.1 GENERAL INFORMATION

1.1.a Type of Manual:

Operator and Field Maintenance Manual.

1.1.b Equipment Name:

Close Quarter Battle Laser-1

1.1.c Purpose of Equipment:

To covertly direct fire using an infrared laser pointer (IR POINT) for soldiers equipped with a Night Vision Device (NVD), or to point out a target using a visible laser (VIS POINT) for soldiers not using a Night Vision Device (NVD).

1.2 REPORTING EQUIPMENT IMPROVEMENT RECOMMENDATIONS

If you have a suggestion to improve the utility and performance of the CQBL-1, let us know. Mail your comments and suggestions to Steiner-Optik, 331 E. 8th St., Greeley, CO 80631 or email: laserlightsinfo@steiner-optics.com

1.3 Steiner 3-Year Laser Device Warranty

On all laser devices, Steiner offers a 3-Year Limited Warranty from the date of purchase that covers all laser, optical and electronic components, materials and workmanship. All warranties are void if the serial number or manufacturer's labels affixed to the product have been removed, or if products have been abused, misused, modified, neglected or have been disassembled prior to return to the manufacturer.

1.4 CROSS REFERENCES

Common Name

Allen Wrench

Battery Cap

Shipping Case

Cotton Swab

Neoprene Jack Plug

O-Ring

Paddle Switch

Battery

Technical Manual

Tape Fastener Loop

Tape Fastener Hook

Official Name

Socket Head Screw Key

Battery Box Cover

Textile Bag

Disposable Applicator

Plug Assembly

Gasket

Remote Cable Switch

CR123A

Operator and Field Maintenance Manual

Fastener, Loop Tape

Fastener, Hook Tape

1.5 LIST OF ABBREVIATIONS

C	Celsius (Centigrade)	mm	Millimeter
CCW	Counter-clockwise	mrad	Milliradians
cm	Centimeters	mW	Milliwatts
CTA	Common Table of Allowance	nm	Nanometers
CW	Clockwise	No	Number
EA	Each	NOHD	Nominal Ocular Hazard Distance
F	Fahrenheit	NSN	National Stock Number
HI	High	NVD	Night Vision Device
ILLUM	Illuminator	O.D.	Optical Density
in	Inches	OIR	Optical Instrument Reticle
IR	Infrared	Para	Paragraph
LBS	Laser Borelight System	PWR	Power
LED	Light Emitting Diode	QTY	Quantity
LO	Low	RAS	Rail Adapter System
m	Meter	RMA	Return Material Authorization
Max	Maximum	SR	Service Representative
Mfr	Manufacturer	TM	Technical Manual
Min	Minimum	VIS	Visible
MOM	Momentary		

CHAPTER 2 – EQUIPMENT DESCRIPTION

2.1 SYSTEM DESCRIPTION

The CQBL-1 is a laser device that features a Class IIIa visible aiming laser (VIS POINT) for daylight and low light operations, as well as a Class I infrared aiming laser (IR POINT) for use with a NVD.

The CQBL-1 emits a highly collimated beam of visible or infrared light for precise aiming of the weapon. The VIS POINT and the IR POINT are coaligned. The VIS POINT can be used to boresight the device without the requirement of a NVD and will simultaneously boresight the IR POINT.

The CQBL-1 can be used as either a handheld pointer or can be weapon mounted using the Integrated Picatinny Mount. In the weapon mounted mode, the CQBL-1 can be used to accurately direct fire as well as identify targets.

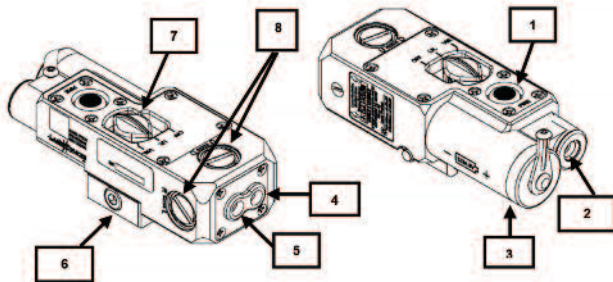

Figure 2-1 CQBL-1 Features

Table 2-1 CQBL-1 Features

ITEM	DESCRIPTION
1	Integrated Momentary Activation Switch
2	Remote Cable Port
3	Battery Cap and Compartment
4	VIS POINT
5	IR POINT
6	Integrated Picatinny Mount
7	Mode Selector Switch
8	Adjusters

2.2 GENERAL CHARACTERISTICS

Table 2.2 Weight, Dimensions, and Performance

WEIGHT

(with battery)	6 oz. / 170 grams
----------------	-------------------

DIMENSIONS

Length	4 in. / 10.2 cm
--------	-----------------

Width	1.5 in. / 3.8 cm
-------	------------------

Height (including mount)	1.1 in. / 2.5 cm
--------------------------	------------------

PERFORMANCE

Laser Wavelength

VIS POINT	635 nm
-----------	--------

IR POINT	850 nm
----------	--------

Output Power (Hi/Lo)

VIS POINT	<5 mW / <1 mW
-----------	---------------

IR POINT	<0.7 mW / <1 mW
----------	-----------------

Beam Divergence

VIS POINT	0.8 mrad
-----------	----------

IR POINT	0.8 mrad
----------	----------

Battery Life	>3 hours
--------------	----------

VIS POINT and IR POINT (STARLIGHT CONDITIONS)

VIS POINT Range (Hi/Lo)	250 m / 5 m
-------------------------	-------------

IR POINT Range:	>250 m
-----------------	--------

2.3 DESCRIPTION OF MAJOR COMPONENTS

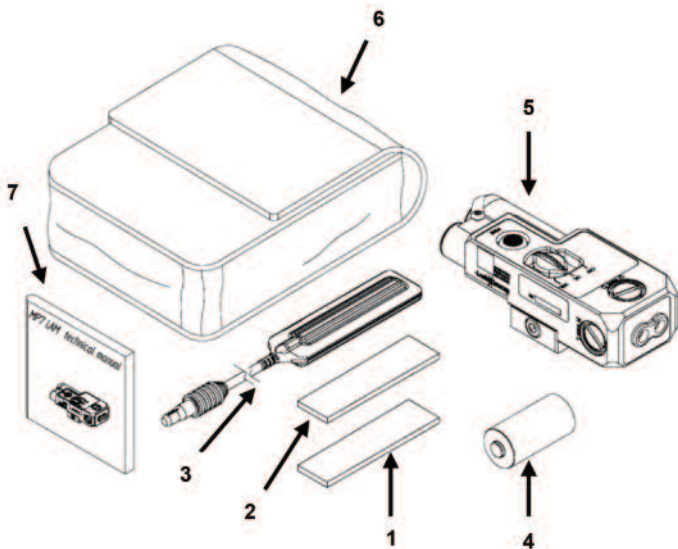

Figure 2-2 CQBL-1 Major Components

Table 2-3 CQBL-1 Major Components

ITEM	DESCRIPTION
1	Tape Fastener Loop 5/8" (Black)
2	Tape Fastener Hook 1/2" (Black) (attached to remote cable switch)
3	Remote Cable Switch, HI Pressure MOM Remote, 7"
4	Battery, CR 123A
5	CQBL-1 Assembly
6	Shipping Case
7	Operator and Field Maintenance Manual

2.3.a Tape Fastener Loop

The Tape Fastener Loop is provided to secure the Remote Cable Switch to the weapon in a position convenient to the user.

2.3.b Tape Fastener Hook

The Tape Fastener Hook is pre-attached by the manufacturer to the pressure pad switch.

2.3.c Remote Cable Switch

The 7 inch Remote Cable Switch allows the user to activate the CQBL-1 in a momentary (MOM) mode by pressing the pressure pad once. Pressing the pressure pad twice in rapid succession will activate the CQBL-1 continuously for 5 minutes. Pressing the pressure pad again will return the unit to momentary activation. The pressure pad provides a tactile (silent) click that indicates when the switch has been activated.

2.3.d Battery

One 3-volt CR 123A lithium battery is used as a power supply for operating the CQBL-1. The use of a high-quality, lithium battery is recommended.

2.3.e CQBL-1 Assembly

The CQBL-1 device provides a visible laser pointer (VIS POINT) and infrared laser pointer (IR POINT). The device is used for aiming, signaling, and command and control.

2.3.f Shipping Pouch

The CQBL-1 is provided with a Shipping Pouch for transport and for storage when not in use.

2.3.g Operator and Field Maintenance Manual

NOTE

You must read the entire Operator and Field Maintenance Manual before operating the CQBL-1 and follow all **WARNINGS, CAUTIONS** and **NOTES**.

The Operator and Field Maintenance Manual provides safety information, equipment information, operating instructions, mounting procedures, zeroing procedures, and maintenance procedures.

CHAPTER III – SECTION I OPERATING INSTRUCTIONS

3.1 GENERAL

3.1.a Battery Installation

WARNING

DO NOT store or ship the CQBL-1 with the battery installed.

All directions, such as CW and CCW, are given from the shooter's perspective, as if the laser were weapon-mounted.

NOTE

Loss or removal of the O-ring from the battery cap may allow water to enter the CQBL-1.

Unscrew the battery cap in a CCW direction. Remove and properly discard the spent battery. Inspect the battery compartment for dirt, moisture and corrosion. Clean the battery compartment as needed (refer to Paragraph 4.3.c). Inspect the O-ring seal on the battery cap to make sure it is free of sand and dirt particles and that it has not been damaged (see Paragraph 4.3.d). Install the battery as indicated by the marking on the CQBL-1 housing. Reinstall the battery cap and hand tighten in a CW direction.



Figure 3-1 Battery Installation

3.2.b Mode Selector Switch

NOTE

The CQBL-1 will not operate if the rotary switch is not precisely aligned with the marked switch position.

In extreme cold temperatures the switch may offer more resistance.

The Mode Selector Switch is located on the top middle of the CQBL-1 Housing. It is used to select between the VIS POINT and IR POINT modes of operation. The selected mode of operation will be activated when either the Remote Cable Switch or the Integrated Momentary Activation Switch is depressed. The Mode Selector Switch has three (3) positions. See Table 3-1.



Figure 3-2 Mode Selector Switch

Table 3-1 Mode Selector Switch Functions

Item #	Switch Position	Activation Method	Use
1	OFF	OFF	The CQBL-1 WILL NOT OPERATE.
2	IR	Activates the IR POINT when the Remote Cable Switch or Integrated Momentary Activation Switch is pressed.	Pressing the pressure pad or momentary switch once will activate the laser in a momentary mode. Pressing the pressure pad or momentary switch twice in rapid succession will activate the CQBL-1 continuously for 5 minutes. Pressing the pressure pad again will return the unit to momentary activation.
3	VIS	Activates the VIS POINT when the Remote Cable Switch or Integrated Momentary Activation Switch is pressed.	Pressing the pressure pad or momentary switch once will activate the laser in a momentary mode. Pressing the pressure pad or momentary switch twice in rapid succession will activate the CQBL-1 continuously for 5 minutes. Pressing the pressure pad again will return the unit to momentary activation.

3.1.c Integrated Momentary Activation Switch

NOTE

Click sound is minimized by depressing the center of the switch.

The Integrated Momentary Activation Switch is located on the top of the CQBL-1 housing above the word FIRE. Firmly pressing and holding the switch activates the CQBL-1 in the mode that is currently selected by the Mode Selector Switch. When the switch is released, the CQBL-1 turns off. Pressing the Integrated Momentary Activation Switch twice in rapid succession will activate the CQBL-1 in a continuous ON mode for 5 minutes. Pressing the Integrated Momentary Activation Switch once again will return the unit to the momentary mode.



Figure 3-3 Integrated Momentary Activation Switch

3.2.d Activation Indicator/Low Battery Indicator

A green LED is located on the rear housing between the battery compartment and the remote cable port. When lit, it indicates that the CQBL-1 is actively emitting laser energy. It also acts as a Low Battery Indicator.

When the Mode Selector Switch is turned to the IR POINT or VIS POINT position, the LED will light up if either the Remote Cable Switch or Integrated Momentary Activation Switch is depressed, indicating that the laser is ON. The LED will remain lit until the Integrated Momentary Activation Switch or Remote Cable Switch is released.

When the Remote Cable Switch or Integrated Momentary Activation Switch has been pressed twice in rapid succession, the LED will light up indicating that the laser is functioning in a constant ON mode. The LED will remain lit for 5 minutes unless the Integrated Momentary Activation or Remote Cable Switch is pressed once again to return the unit to momentary activation.

If the LED starts to blink, the battery should be replaced.

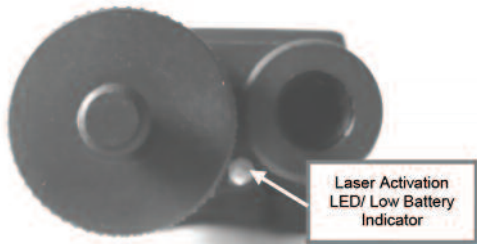

Figure 3-4 Laser Activation LED / Low Battery Indicator

3.2.e Remote Cable Switch

CAUTION

DO NOT remove the Remote Cable Switch by pulling on the cable.

NOTE

When installing the Remote Cable Switch, gently twist the plug into the remote cable port.

Ensure the Mode Selector Switch is in the OFF position before inserting the Remote Cable Switch.

The CQBL-1 Mode Selector Switch must be turned to VIS POINT or IR POINT setting to use the Remote Cable Switch.

CQBL-1 will not operate if the rotary switch is not precisely aligned with the marked switch position.

The Remote Cable Switch plugs into the back of the CQBL-1 for weapon mounted use. Depressing the Remote Cable Switch activates the CQBL-1 in the operational mode selected by the Mode Selector Switch. When the remote cable switch is released, the CQBL-1 turns off.

In the Momentary Mode when the Remote Cable Switch has been pressed twice in rapid succession, the CQBL-1 will activate in a constant ON mode for 5 minutes or until the Remote Cable Switch is pressed once again to return the unit to momentary activation.

When the Remote Cable Switch is installed into the CQBL-1, it automatically locks in place. To remove it, grasp the Plug Sleeve and pull straight back. Do not remove the Remote Cable Switch by pulling on the cable.

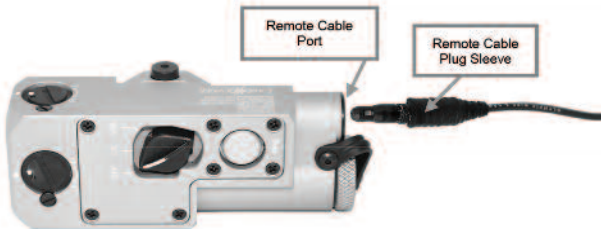

Figure 3-5 Installation of Remote Cable Switch

3.2.f Adjusters

CAUTION

DO NOT over adjust the adjusters by forcing them beyond their end of travel.

NOTE

- The mission will dictate which aiming laser (VIS POINT / IR POINT) will be boresighted to achieve maximum accuracy.
- Always move the adjusters slowly, one click at a time, to prevent the adjuster from jumping detents.
- In extreme cold temperatures the adjusters may offer more resistance.

The adjuster may offer some resistance as you turn it in a CW direction from the factory neutral position. When the adjuster is harder to turn it has reached the maximum CW travel.

When the adjuster is at its maximum CW or CCW point of travel and turned in the opposite direction the laser point may trace a small loop on the target. This is normal and does not indicate a failure condition.

A positive load is required on the adjustment mechanism when boresighting/zeroing the CQBL-1 for purposes of retaining the set alignment. The adjuster knobs on the CQBL-1 may vary slightly in the force required to turn the adjusters. This is normal and does not indicate a failure condition.

NOTE

At the maximum CW or CCW travel, the CQBL-1 lasers may not move a full 1 cm per click, or may jump squares on the target. If this happens the CQBL-1 should be returned to its factory neutral preset as described in Section 3.5.

CQBL-1 is for use on weapons where the MIL-STD-1913 rail is parallel with the bore of the weapon. In the factory neutral position the VIS POINT / IR POINT should project on the same side of the target as the laser is mounted and must fall within a 1.5 mrad circle at 25 meters.

The CQBL-1 is equipped with boresight adjusters for adjusting the VIS POINT and IR POINT for elevation and azimuth. Each adjuster click will move the laser point by 1 cm at 25 meters.

The VIS POINT / IR POINT adjuster guards are marked with arrows and the letters U/D and R/L indicating the direction that the shot group will move if an adjuster is turned when the laser is mounted in the horizontal (top) position. The adjusters will move the VIS POINT / IR POINT approximately 10" or 25 cm in each direction from the factory neutral preset position at 25 meters.

The VIS POINT and the IR POINT are adjusted using the same adjusters. Zeroing the VIS POINT will align the IR POINT and vice versa. For improved accuracy, always align the primary laser expected to be used on the mission.

NOTE

At the maximum CW or CCW travel the CQBL-1 lasers may not move a full 1 cm per click, or may jump squares on the target. If this happens the CQBL-1 should be returned to its factory neutral preset as described in Section 3.5.

CQBL-1 is for use on weapons where the MIL-STD-1913 rail is parallel with the bore of the weapon. In the factory neutral position the VIS POINT / IR POINT should project on the same side of the target as the laser is mounted and must fall within a 1.5 mrad circle at 25 meters.

The CQBL-1 is equipped with boresight adjusters for adjusting the VIS POINT and IR POINT for elevation and azimuth. Each adjuster click will move the laser point by 1 cm at 25 meters.

The VIS POINT / IR POINT adjuster guards are marked with arrows and the letters U/D and R/L indicating the direction that the shot group will move if an adjuster is turned when the laser is mounted in the horizontal (top) position. The adjusters will move the VIS POINT / IR POINT approximately 10" or 25 cm in each direction from the factory neutral preset position at 25 meters.

The VIS POINT and the IR POINT are adjusted using the same adjusters. Zeroing the VIS POINT will align the IR POINT and vice versa. For improved accuracy, always align the primary laser expected to be used on the mission.

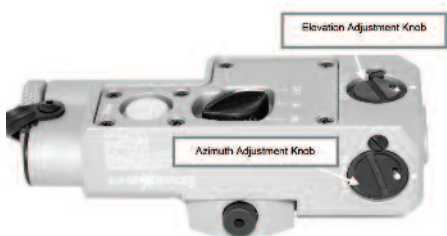

Figure 3-6 Adjusters for VIS and IR POINT

VIS POINT and IR POINT Adjustment

Table 3-3 indicates the direction of adjuster rotation and resultant shot group movement for zeroing the VIS POINT or IR POINT to the weapon when the CQBL-1 is Top Mounted.

The VIS POINT and IR POINT are co-aligned. Zeroing the VIS POINT will simultaneously zero the IR POINT and vice versa.

Table 3-2 Adjuster Rotation and Shot Group Movement for the Visible Pointer and IR pointer (Side Mounted-Left)

ZEROING THE AIMING LASER	Adjuster Movement	Shot Group Movement
Top Adjuster Elevation (guard marked U/D)	CW CCW	Up Down
Side Adjuster Windage (guard marked R/L)	CW CCW	Right Left

When adjusting in a CCW direction, apply a positive load to the adjuster by turning an additional 1/4 turn (8 clicks) CCW, then make the final boresighting/zeroing adjustments by turning the adjusters in a CW direction. No positive load is required when adjustments are made in the CW direction.

CHAPTER III – SECTION II MOUNTING PROCEDURES

3.2 MOUNTING PROCEDURES

WARNING

Be sure the weapon is CLEAR and on SAFE before proceeding.

NOTE

The CQBL-1 may be placed at any position (forward and aft) on the rail that is convenient for the operator. If the CQBL-1 is removed from the rail, the operator must take note of the position at which it was zeroed, and return it to the same position in order to ensure that zero is retained.

Failure to fully tighten the Integrated Picatinny Mount will cause zero retention problems. Insure that the base mount is fully seated on the MIL-STD-1913 rail with NO front or rear overhang.

The CQBL-1 is for use on weapons where the MIL-STD-1913 rail is parallel with the bore of the weapon. In the factory neutral position the VIS POINT / IR POINT should project on the same side of the target as the laser is mounted and must fall within a 1.5 mrad circle at 25 meters. See Section 3.5.

An Integrated Picatinny Mount is used to attach the CQBL-1 to weapons equipped with a MIL-STD-1913 rail. Place the unit far enough back on the rail to allow for battery replacement without removal from the weapon. If removed, the CQBL-1 must be returned to the same position on the rail to retain zero.

The CQBL-1 may be mounted on the Top, Left, or Right rail using the Rail Grabber mount.



Figure 3-7 Integrated Picatinny Mount Configuration

Place the grabber rail against the right side of the MIL-STD-1913 rail and align the crossbolt on the bottom of the mount with a slot on the rail. Push forward on the CQBL-1 so that the crossbolt contacts the front of the slot on the MIL-STD-1913 rail. Tighten the hex head screw so that the body of the laser housing is secure to the rail.

Install the Remote Cable Switch in a convenient location.

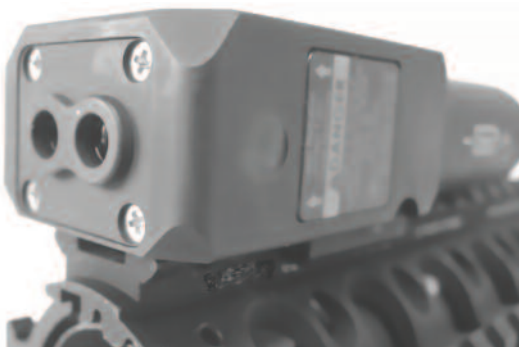

Figure 3-8 CQBL-1 Mounted MIL-STD-1913 Rail

CHAPTER III – SECTION III ZEROING PROCEDURES

This section provides zeroing instructions for the CQBL-1 using the AA Laser Borelight, Item No. 9090 on a 25-meter range.

3.3 PLACING A POSITIVE LOAD ON THE ADJUSTERS

CAUTION

DO NOT over-adjust the adjusters by forcing them beyond their end of travel.

NOTE

ALWAYS Zero the CQBL-1 starting with the Adjuster marked U/D.

When moving the adjusters, make sure that the adjustment mechanism has engaged a detent and has not stopped between detents. Failure to properly engage a detent may impact accuracy as the laser may move when the weapon is fired.

Positive Load is required anytime an adjustment to VIS POINT or IR POINT is made in a CCW direction. A Positive Load is not required when making a CW adjustment.

Positive Load is the controlled compression of the spring within the adjuster mechanism to insure the highest level of accuracy is maintained after the weapon is zeroed.

3.5 FACTORY NEUTRAL PRESET

CAUTION

DO NOT over-adjust the adjusters by forcing them beyond their end of travel.

NOTE

ALWAYS zero the CQBL-1 starting with the Adjuster marked U/D.

When moving the adjusters, make sure that the adjustment mechanism had engaged a detent and has not stopped between detents. Failure to properly engage a detent may adversely impact accuracy as the laser may move to the next detent when the weapon is fired.

The adjuster may offer some resistance as you turn it in a CW direction from the factory neutral position. When the adjuster is harder to turn it has reached the maximum CW travel.

The CQBL-1 is preset at the factory to a neutral position. In the neutral position the laser beam is parallel to the bore of the weapon. The VIS POINT / IR POINT can be returned to the factory alignment (neutral position) using the following procedure:

Turn the adjuster marked U/D CCW to the stop.

Turn the adjuster CW until the white dot on the adjuster aligns with the white dot on the unit housing (approximately 3/4 turn).

Turn the adjuster marked R/L CCW to the stop.

Turn the adjuster CW until the white dot on the adjuster aligns with the white dot on the unit housing (approximately 3/4 turn).

3.6 BORESIGHT USING THE AA BORELIGHT SYSTEM

CAUTION

DO NOT over-adjust the adjusters by forcing them beyond their end of travel.

NOTE

The mission will dictate which aim laser (VIS POINT / IR POINT) will be boresighted to achieve maximum accuracy.

Always move the adjusters slowly, one click at a time, to prevent the adjuster from jumping detents.

In extreme cold temperatures the adjusters may offer more resistance.

The adjuster may offer some resistance as you turn it in a CW direction from the factory neutral position. When the adjuster is harder to turn it has reach the maximum CW travel.

When the adjuster is at its maximum CW or CCW point of travel and is turned in the opposite direction the laser point may trace a small loop on the target. This is normal and does not indicate a failure condition.

A positive load is required on the adjustment mechanism when boresighting/zeroing the CQBL-1 to retain the set alignment.

The adjuster knobs on the CQBL-1 may vary slightly in the force required to turn the adjusters. This is normal and does not indicate a failure condition.

At the maximum CW or CCW travel the CQBL-1 lasers may not move a full 1 cm per click, or may jump squares on the target. If this happens the CQBL-1 should be returned to its factory neutral preset.

CQBL-1 is for use on weapons where the MIL-STD-1913 rail is parallel with the bore of the weapon. In the factory neutral position the VIS POINT / IR POINT should project on the same side of the target as the laser is mounted and must fall within a 1.5 mrad circle at 25 meters.

Refer to the Borelight Operator's Manual for instructions on creating boresight targets. Each adjuster click moves the strike point 1 cm at 25 meters.

CHAPTER IV – SECTION I PREVENTIVE MAINTENANCE CHECKS

4.1 GENERAL

NOTE

Perform functional tests in the order listed in Table 4-1. Operating Procedures are detailed in Chapter III, Section I.

Functional testing of the CQBL-1 to ensure proper operation should be performed in a dark room or area away from light. Viewing of IR beams must be performed with a NVD, (AN/PVS-7 or AN/PVS-14).

4.1.a Warnings and Cautions

Always observe the WARNINGS and CAUTIONS appearing in the table.

4.1.b Explanation of Table Entries

1. Item Number

Numbers in this column are for reference. Item numbers also appear in the order that you must perform the checks and services listed.

2. Interval

This column tells you when you must do the procedure in the procedure column. BEFORE (B) PROCEDURES must be done before you operate or use the equipment. DURING (D) PROCEDURES must be done during the time you are operating or using the equipment. AFTER (A) PROCEDURES must be done immediately after you have operated or used the equipment.

3. Item to Check/Service

This column provides the item to be checked or serviced.

4. Procedure

This column gives the procedure you must do to check the item.

5. Not Fully Mission Capable If

Information in this column tells you what faults will keep your equipment from being capable of performing its primary mission.

Be sure to observe all special information and notes that appear in your table.

Table 4-1 Preventive Maintenance Checks and Services

Item No.	Interval	Item to Check/Service	Procedure	Not Fully Mission Capable If:
1	B/D/A	CQBL-1 Exterior	-Check housing for separation between the front and the rear section of the housing, missing screws and switch knobs, azimuth and elevation adjuster covers.	A gap appears between the front and the rear section of the housing, missing switch knobs, or adjuster covers.
2	B/A	Adjusters	-Check for broken, missing or stripped Adjusters.	Adjusters broken, missing or stripped or laser fails to move.
3	B/D/A	Integrated Picatinny Mount	-Check attachment to housing, broken, missing parts. -Inspect grabber rail and crossbolt for dirt and corrosion. -If laser is loose on the rail: Move to a different position on the rail; Move to a different rail on weapon; Replace the rail on weapon.	Thumb screw mount loose, missing parts or broken.
4	B/D/A	Remote Cable Port	-Check for mud or dirt and clean as needed.	

Table 4-1 Preventive Maintenance Checks and Services

Item No.	Interval	Item to Check/Service	Procedure	Not Fully Mission Capable If:
5	B/A	Battery Compartment	-Check for corrosion, presence of O-ring, spring, battery cap lanyard. Inspect threads for dirt or damage.	Corroded or broken contacts.
6	B/A	Battery Compartment O-Ring	-Check O-ring for cuts, cracks. -Lubricate as needed.	
7	B/A	Install CR123A Battery	-Install a known good battery	
8	B/A	Mode Selector Switch and Integrated Momentary Activation Switch	-Select VIS POINT using the Mode Selector Switch. -Depress the Remote Cable Switch or use the Integrated Momentary Activation Switch and observe the beam spot on wall.	Mode Selector Switch inoperative with the VIS POINT Beam Spot not visible through all selections. Integrated Momentary Activation Switch Inoperative

Table 4-1 Preventive Maintenance Checks and Services

Item No.	Interval	Item to Check/Service	Procedure	Not Fully Mission Capable If:
9	B	Boresight Alignment	-Confirm that the IR POINT or VIS POINT can be boresighted/zeroed on the weapon on which it will be mounted. -Check to make sure that the VIS POINT / IR POINT projects on the same side of the target as the laser is mounted and falls within 1.5mrad circle at 25 meters. See Section 3.5.	
10	B/D/A	LED Status Indicator	-Observe green LED is lit and does not flash when lasing.	
11	B/A	Remote Cable Switch	-Insert the remote cable switch and activate the laser.	
12	A	Battery	-Remove battery.	

CHAPTER IV – SECTION II TROUBLESHOOTING

4.2 GENERAL

The purpose of troubleshooting is to systematically search and identify the source of a problem. The most frequent equipment malfunctions, probable causes and corrective actions for the CQBL-1 are listed in Table 4-2. Perform the tests, inspections and corrective actions in the order they are listed. This manual does not list all malfunctions, tests, inspections, or corrective actions that may occur.

Table 4-1 Preventive Maintenance Checks and Services

Malfunction Para.	Test / Inspection	Corrective Action	Ref.
1. VIS POINT/ IR POINT beams fail to come on or stay on.	a. Ensure Mode Selector Switch is in proper position and either the Remote Cable Switch or Integrated Momentary Activation Switch is depressed.	-Properly align switches	3.2.b 3.2.c
	b. Verify battery installation.	-Tighten battery cap -Install new battery	3.2.a
	c. Inspect battery cap for damage or corrosion.	-Notify Unit Maintenance.	5.2.a
	d. Inspect battery contact spring in the battery compartment for damage or corrosion.	-Notify Unit Maintenance.	5.2.a
	e. Possible internal failure.	Notify Unit Maintenance.	5.2.a
2. VIS POINT/ IR POINT beams have become weak (not as bright).	b. Verify proper battery installation.	-Tighten battery cap -Install new battery	3.2.a
3. Low Battery Indicator Light remains on when new battery is installed.	a. Inspect battery compartment for corrosion.	-Clean battery compartment.	4.3.b
	b. Inspect Battery Cap contact for corrosion.	-Clean battery cap.	4.3.c
	c. Inspect battery cap and housing threads for contamination.	-Clean battery cap and housing threads.	4.3.c

Table 4-1 Preventive Maintenance Checks and Services

Malfunction	Test / Inspection	Corrective Action	Ref. Para.
4. VIS POINT / IR POINT beams DO NOT move.	a. Verify adjuster function	-Clean as required. -Notify Unit Maintenance.	4.3.a 5.2.a
5. Remote Cable Switch inoperable, but Integrated Momentary Activation Switch functions.	a. Inspect Remote Cable Port for dirt or debris. b. Inspect Remote Cable Plug for damaged contacts. c. Possible remote cable failure.	-Clean remote cable port. -Replace remote cable assembly. -Replace remote cable. -Notify Unit Maintenance.	3.2.e 3.2.e 3.2.e 5.2.a
6. Laser cannot be aligned, moves on the rail, or the laser when reset to the factory neutral position fails to project the VIS POINT/ IR POINT on the same side of the target as the laser is mounted and does not fall within 1.5mrad circle at 25 meters.	a. Inspect weapon system rail.	-Refer to appropriate weapons TM.	

CHAPTER IV – SECTION III OPERATOR MAINTENANCE

4.3 GENERAL

WARNING

DO NOT store the CQBL-1 with the battery installed.

CAUTION

The use of gun cleaning agents that contain perchloroethylene or methylene chloride may permanently damage the CQBL-1 system.

The CQBL-1 is a rugged, compact laser device that is designed to operate in severe military environments. The exterior housing is made of aircraft grade aluminum and the outer components are made of chemically resistant materials that will not be harmed by chemicals normally encountered during military operations. Operator maintenance is limited to the inspection and cleaning of the CQBL-1 external surfaces, replacement of the battery before each mission and removal of the battery after each mission.

4.3.a External Cleaning

Clean the exterior of the CQBL-1 by flushing with water and wiping with a clean, soft cloth. Cleaning should be done whenever the CQBL-1 becomes dirty or after exposure to saltwater.

4.3.b Battery Compartment

Before each use, inspect the battery and battery compartment for dirt, dust or corrosion. Clean the battery compartment by wiping with a soft, clean cloth. If a damp cloth is used to clean the battery compartment make sure to allow the compartment to air dry completely before reinstalling the battery cap.

4.3.c Battery Cap

Prior to water operations or emersion, inspect the O-ring and the battery cap to make sure they are free of dirt, moisture or corrosion. Thoroughly clean the O-rings, battery cap and back of the battery compartment that seals against the O-ring using Isopropyl Alcohol. After cleaning, or if the O-ring becomes dried out, lubricate the O-ring using silicone grease. If the O-ring becomes cut or nicked, it should be replaced.

To remove the Battery Cap Retaining Strap, stretch the end of the Retaining Strap over the retaining screw head. To install, stretch the end of the retaining strap over the stud located on the battery cap.

4.3.d Battery Compartment and Housing Threads

Inspect threading on the battery cap and housing for contamination. If the threading appears to be oily or dirty, clean with Isopropyl Alcohol using a soft, clean cloth.

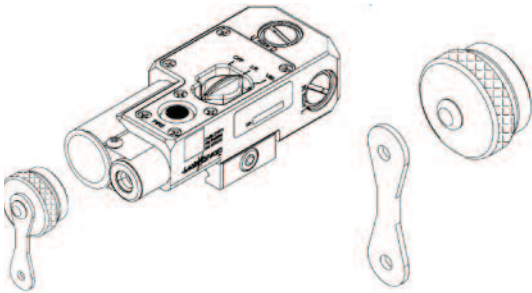

Figure 4-1 Remove and Replace Battery Cap and Battery Cap Retaining Strap

4.3.e Battery Removal and Replacement

Refer to Chapter III, Paragraph 3.2.a for Battery Installation procedures. No special tools or equipment are required to replace the battery.

4.3.f Replace Remote Cable

See Chapter III, Paragraph 3.2.e for replacement of the Remote Cable Switch.

4.3.g Remove and Replace Battery Cap O-ring

See Chapter III, Paragraph 3.2.a for procedures. Figure 4-1 depicts the removal and installation of the battery.

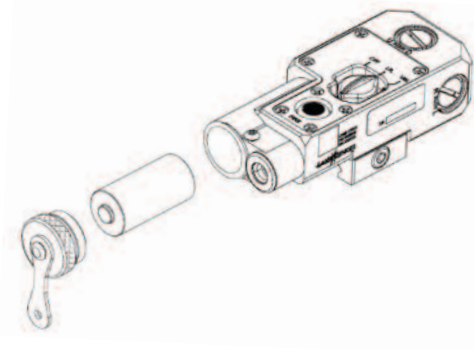

4.3.g Remove and Replace Battery Cap O-ring

NOTE

NEVER use a sharp or metal object to remove O-rings as they may damage the O-ring or the O-ring groove contact surface.

Inspect the O-ring for nicks, cracks, cuts or abrasion. Also check to make sure that it feels soft. If damaged, replace the O-ring.

To remove pull the O-ring out of the groove at the base of the threaded portion of the battery cap and remove. Install the new O-ring by pulling it onto the battery cap so that it fits in the groove located at the base of the threaded portion of the battery cap.

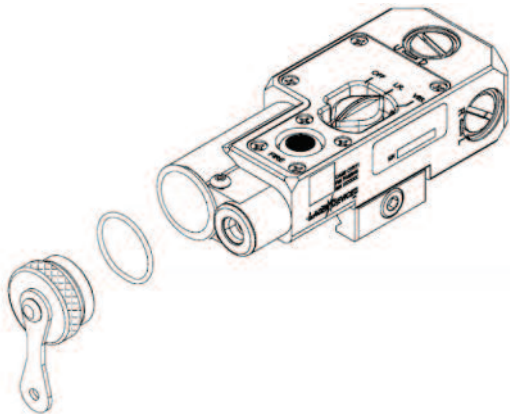

Figure 4-3 Remove and Replace Battery Cap O-ring

CHAPTER V – SERVICE/PACKING AND UNPACKING

5.1 Steiner 3-Year Laser Device Warranty

On all laser devices, Steiner offers a 3-Year Limited Warranty from the date of purchase that covers all laser, optical and electronic components, materials and workmanship. All warranties are void if the serial number or manufacturer's labels affixed to the product have been removed, or if products have been abused, misused, modified, neglected or have been disassembled prior to return to the manufacturer.

5.2 Warranty or Repair Service

5.2.a If you require warranty or repair service please contact Steiner Optik, and we will determine the best way to fix your device. For more information, email laserlightsinfo@steiner-optics.com or call 888-288-7747.

5.2.b To assist the Customer Service with determining if the item is repairable, please provide the following information:

1. Serial Number of the defective item
2. Thorough description of the malfunction, defect or damage
3. An explanation as to how the malfunction, defect or damage occurred, if known.

If Steiner determines that the item is under warranty or should be returned for repair, a Return Material Authorization (RMA) number will be provided.

5.2.c When returning the CQBL-1 for service or repair, the following procedures should be followed to prevent any additional damage:

1. Be sure that the CQBL-1 is free of all contaminants such as dirt or any other foreign material.
2. Remove the battery.
3. Place the CQBL-1 in the Shipping Case or Carrying Case if available. If the Shipping Case is not available, individually package each CQBL-1 unit being returned in a suitable container.

5.2.d Place the CQBL-1 and a copy of the test report or detailed description of the failure in a suitable packing/shipping container. Mark the package with the RMA number. Ship by the fastest, traceable, prepaid means to the address provided by Steiner Customer Service.

APPENDIX A REPAIR PARTS

Table A-1 Repair Parts List (CQBL-1)

Item No.	Description	QTY
1	Remote Cable Switch, 7"	1
2	Loop Tape	1
3	Battery Cap	1
4	Strap, Battery Cap	1
5	O-Ring	1
6	Screw	1
7	Rail Clamp	1
8	Lock Washer	1
9	Cross Bolt Screw	1
10	Retaining Ring 9/64"	1

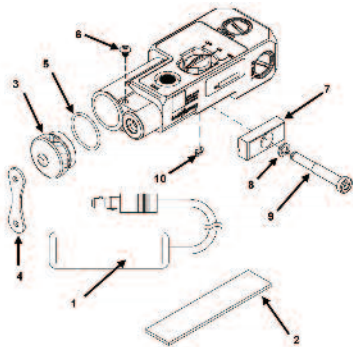



STEINER-OPTIK

331 East 8th Street • Greeley, CO 80631

Tel: (888) 228-7747 • Fax: (970) 356-8702

Customer Service: laserlightsinfo@steiner-optics.com

steiner-optics.com