

DBAL-D²



Technical Manual

DUAL BEAM LASER SYSTEM

WITH VISIBLE LASER POINTER / IR LASER PLUS EYE-SAFE IR LED ILLUMINATOR

STEINER 
Nothing Escapes You

TABLE OF CONTENTS

	Page
SAFETY SUMMARY	2
HOW TO USE THIS MANUAL	9
GENERAL INFORMATION	10
EQUIPMENT DESCRIPTION	13
SECTION I OPERATING INSTRUCTIONS	19
SECTION II MOUNTING PROCEDURES	33
SECTION III BORESIGHTING/ZEROING PROCEDURES.....	36
SECTION I USER PREVENTIVE MAINTENANCE CHECKS	44
SECTION II TROUBLESHOOTING	49
SECTION III MAINTENANCE.....	52
SERVICE/PACKING AND UNPACKING.....	60
APPENDIX A REPAIR PARTS.....	62

SAFETY SUMMARY

This safety summary contains general safety warnings and hazardous materials warnings that must be understood and applied during operation and maintenance of this equipment. Failure to observe these precautions could result in serious injury or death to personnel. Also included are explanations of safety and hazardous materials icons used within this technical manual. Table a-1 contains the safety data conforming to the United States (US) Food and Drug Administration (FDA) Code of Federal Regulations Title 21.

EXPLANATION OF SAFETY WARNINGS ICONS



ACCIDENTAL DISCHARGE - hazard symbol indicates extreme danger for personnel from weapons fire.



EXPLOSION - hazard symbol shows that the material may explode if obstructed.



EYE INJURY - laser light hazard symbol indicates extreme danger for eyes from laser beams and reflections.

EXPLANATION OF SAFETY ALERTS

WARNING

Identifies a clear danger to the person doing that procedure.

CAUTION

Identifies risk of damage to the equipment.

NOTE

Used to highlight essential procedures, conditions, statements, or convey important instructional data to the user.

WARNING

**INVISIBLE LASER RADIATION
AVOID DIRECT EXPOSURE TO THE BEAM**

**GREEN VISIBLE LASER POINTER - Class IIIa
LASER WAVELENGTH: 532 nm
OUTPUT: <5 mW**

- DO NOT stare into the laser beam.
- DO NOT look into the laser beam through binoculars or telescopes.
- DO NOT point the laser beam at mirror-like surfaces.
- DO NOT shine the laser beam into other individual's eyes.



WARNING

**INVISIBLE LASER AND LED RADIATION
AVOID DIRECT EXPOSURE TO THE BEAMS**

IR LASER POINTER - CLASS I

LASER WAVELENGTH: 850 nm

OUTPUT: IR LASER: <0.7 mW

OUTPUT: ILLUMINATOR: <600 mW - EYE SAFE

- DO NOT stare into the infrared beam.
- DO NOT look into the infrared beam through binoculars or telescopes.
- DO NOT point the infrared beam at mirror-like surfaces.
- DO NOT shine the infrared beam into other individual's eyes.



Safety Data

US FDA Code of Federal Regulations (CFR) Title 21

LASER	Power Output	SAFETY CLASS	NOHD (m)
5mW GREEN Pointer			
Low Power	<1 mW	IIIa	17.1
High Power	<5 mW		45
0.7mW IR Pointer			
Power	<0.7 mW	Class I	0
600mW Illuminator			
Low Power	<300 mW	Eye Safe	0
High Power	<600 mW	Eye Safe	0

**WARNING**

Be sure the weapon is CLEAR and on SAFE before proceeding.

**WARNING**

DO NOT store the DBAL-D² with the battery installed.

**WARNING**

Ensure the Activation Mode Selector Switch is in the OFF position before inspecting the Exit Port Lenses. If the Activation Selector Switch is not in the OFF position, the laser may be inadvertently activated by depressing the fire button on the back of the housing.

**WARNING**

If a Laser Borelight is used to boresight the DBAL-D², be sure to remove the Borelight from the weapon prior to firing.

**WARNING**

NEVER boresight in the High Power mode of operation.

CAUTION

DO NOT over-adjust the laser adjusters by forcing them beyond their end of travel.

CAUTION

Use ONLY authorized weapons cleaning supplies; permanent damage may occur.

CAUTION

DO NOT remove the Remote Cable Switch by pulling on the cable; clasp the cable plug assembly.

HOW TO USE THIS MANUAL

Usage

You must familiarize yourself with the entire manual before operating the equipment. Read the complete maintenance task before performing maintenance and follow all **WARNINGS, CAUTIONS** and **NOTES**.

Manual Overview

The manual contains sections for Operating and Maintaining the DBAL-D² and laser safety.

Appendix A Repair Parts

CHAPTER 1—GENERAL INFORMATION

1.1 GENERAL INFORMATION

1.1.a Type of Manual:

Operator and Field Maintenance Manual.

1.1.b Equipment Name:

Dual Beam Aiming Laser-D².

1.1.c Purpose of Equipment:

To covertly illuminate and direct fire using an infrared (IR) laser pointer (POINT) and IR LED illuminator (ILLUM) for users equipped with a Night Vision Device (NVD), or to direct fire using a visible (VIS) red or green laser pointer for users not using a NVD.

1.1.d Specifications:

Specifications contained in this manual are subject to change without notice.

1.2 REPORTING EQUIPMENT IMPROVEMENT RECOMMENDATIONS

If you have a suggestion to improve the utility and performance of the DBAL-D², let us know. Mail your comments and suggestions to Steiner-Optik, 331 E. 8th St., Greeley, CO 80631 or email: laserlightsinfo@steiner-optics.com

5.1 Steiner 3-Year Laser Device Warranty

On all laser devices, Steiner offers a 3-Year Limited Warranty from the date of purchase that covers all laser, optical and electronic components, materials and workmanship. All warranties are void if the serial number or manufacturer's labels affixed to the product have been removed, or if products have been abused, misused, modified, neglected or have been disassembled prior to return to the manufacturer.

1.4 CROSS REFERENCES

Common Name

Battery Cap

Shipping Case

Cotton Swab

Lens Covers

Paddle Switch

Battery

Technical Manual

Tape Fastener Loop

Tape Fastener Hook

Official Name

Battery Box Cover

Shipping Box

Disposable Applicator

Exit Port Covers

Remote Cable Switch

CR 123A

Operator and Field Maintenance Manual

Fastener, Loop Tape

Fastener, Hook Tape

1.5 LIST OF ABBREVIATIONS

C	Celsius (Centigrade)	mm	Millimeter
CCW	Counter-clockwise	mrad	Milliradians
cm	Centimeters	mW	Milliwatts
CTA	Common Table of Allowance	nm	Nanometers
CW	Clockwise	No	Number
EA	Each	NOHD	Nominal Ocular Hazard Distance
F	Fahrenheit	NSN	National Stock Number
HI	High	NVD	Night Vision Device
ILLUM	Illuminator	O.D.	Optical Density
in	Inches	OIR	Optical Instrument Reticle
IR	Infrared	Para	Paragraph
LBS	Laser Borelight System	PWR	Power
LED	Light Emitting Diode	QTY	Quantity
LO	Low	RAS	Rail Adapter System
m	Meter	RMA	Return Material Authorization
Max	Maximum	SR	Service Representative
Mfr	Manufacturer	TM	Technical Manual
Min	Minimum	VIS	Visible
MOM	Momentary		

CHAPTER 2 – EQUIPMENT DESCRIPTION

2.1 SYSTEM DESCRIPTION

The DBAL-D² is a Class IIIa laser device that features a visible pointer (VIS POINT) for daylight and low light operations, as well as an infrared (IR) pointer (IR POINT) and IR LED illuminator (IR ILLUM) for use with a NVD. The visible pointer may be activated in:

- High power mode (H V) or
- Low power mode (L V).

The IR beams may be activated individually or in combination:

- High power IR POINT (IP),
- High power IR POINT and low power IR ILLUM (IP/L),
- High power IR POINT and high power IR ILLUM (IP/H), or High power IR ILLUM (H IL).

The DBAL-D² emits a highly collimated beam of IR light for precise aiming of the weapon and an IR LED illuminator for projecting light on the target or target area. The IR LED illuminator is equipped with an adjustable bezel to vary the size of the illumination beam based on the size of and distance to the target. For long range targets, focus IR LED illuminator at 2°. For short range wide illumination, defocus illuminator to 30°. The visible pointer and

the IR pointer are co-aligned. The visible pointer may be used to boresight the device without the requirement of a NVD and will simultaneously boresight the IR pointer.

The DBAL-D² may be weapon mounted using the Quick Release Mount. The DBAL-D² may be used to accurately direct fire as well as illuminate and identify targets. Figure 2-1 identifies the distinguishing parts of the DBAL-D². Table 2-1 provides performance specifications.

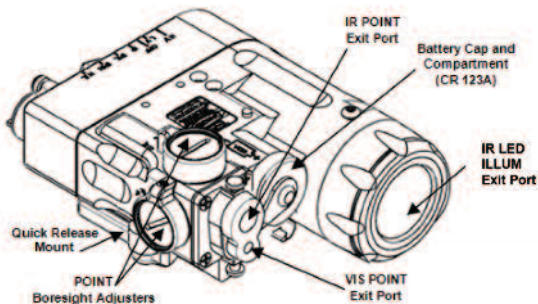

Figure 2-1 DBAL-D² Features

2.2 GENERAL CHARACTERISTICS

Table 2.2 Weight, Dimensions, and Performance

WEIGHT

(with one battery, 3-volt CR 123A)	12.5 oz / 354.4 grams
------------------------------------	-----------------------

DIMENSIONS

Length	3.95 in / 10.03 cm
--------	--------------------

Width	3.37 in / 8.56 cm
-------	-------------------

Height (including mounting bracket)	1.59 in / 4.04 cm
-------------------------------------	-------------------

PERFORMANCE

Wavelength

Green Visible Pointer	532 nm
-----------------------	--------

IR Laser	850 nm
----------	--------

IR LED illuminator	850 nm
--------------------	--------

Output Power

Visible Pointer	Low	0.6 mW
-----------------	-----	--------

High	<5 mW
------	-------

IR Laser	0.7 mW
----------	--------

IR LED illuminator	600 mW
--------------------	--------

Immersion

Waterproof	>5 m
------------	------

VISIBLE and IR LASER (STARLIGHT CONDITIONS)

Green Visible Pointer (<5mW)	15 m / 750 m
------------------------------	--------------

IR Laser (0.6mW)	>250 m
------------------	--------

IR LED ILLUMINATOR (STARLIGHT CONDITIONS)

IR LED illuminator (<600mW)	High > 1000 m	Low ≤ 300 m
-----------------------------	---------------	-------------

2.3 DESCRIPTION OF MAJOR COMPONENTS

Figure 2-2 shows the key components included in the DBAL-D² package.

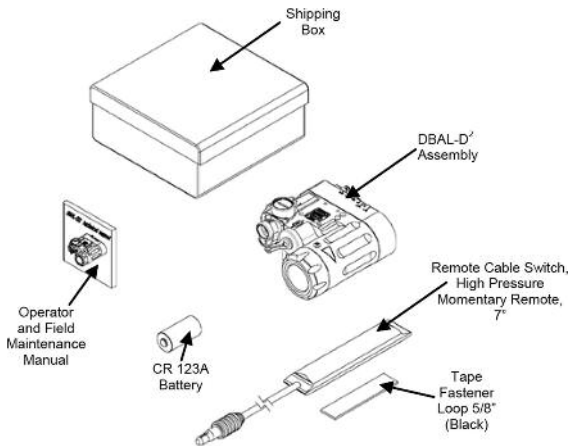

Fig. 2-2 DBAL-D² Major Components

2.3.a Shipping Box

The DBAL-D² is provided in a plastic shipping box with foam insert.

2.3.b DBAL-D² Assembly

The DBAL-D² device provides a visible pointer, IR pointer, and adjustable focus IR LED illuminator. The device is used for aiming, signaling, command and control and for purposes of supplying supplemental IR illumination.

2.3.c Remote Cable Switch

A 7" straight Remote Cable Switch activates the DBAL-D² in a momentary (MOM) mode by depressing the pressure pad once. Pressing the pressure pad twice in rapid succession will activate the device continuously for 5 minutes. Pressing the pressure pad again will return the device to momentary activation. The pressure pad provides a tactile (silent) click that indicates when the switch has been activated. A Tape Fastener Hook is pre-attached by the manufacturer to the pressure pad switch and is used to secure the Remote Cable Switch to the weapon in a position convenient to the user.

2.3.d Tape Fastener Loop

The Tape Fastener Loop is provided to secure the Remote Cable Switch to the weapon in a position convenient to the user.

2.3.e Battery

One CR 123A Lithium battery is used as a power supply for operating the DBAL-D². The use of a high-quality battery is recommended.

2.3.f Operator and Field Maintenance Manual

NOTE

You must read the entire Operator and Field Maintenance Manual before operating the DBAL-D² and follow all **WARNINGS, CAUTIONS** and **NOTES**.

The Operator and Field Maintenance Manual provides safety information, equipment information, operating instructions, mounting procedures, zeroing procedures, and maintenance procedures.

CHAPTER III – SECTION I OPERATING INSTRUCTIONS

3.1 DBAL-D² CONTROLS AND INDICATORS

This section contains a description of the controls and adjustments for the DBAL-D².

3.1.a Battery Installation



WARNING

DO NOT store the DBAL-D² with the battery installed.

NOTE

Loss or removal of the O-ring from the battery cap may allow water to enter the DBAL-D².

Unscrew the battery cap in a CCW direction. Remove and properly discard the spent battery. Inspect the battery compartment for dirt, moisture and corrosion. Clean the battery compartment as needed (refer to Paragraph 4.3.c). Inspect the O-ring seal on the battery cap to make sure it is free of sand and dirt particles and that it has not been damaged. Install the battery as indicated by the marking on the DBAL-D² housing (see Figure 3-1). Reinstall the battery cap and hand tighten in a CW direction.

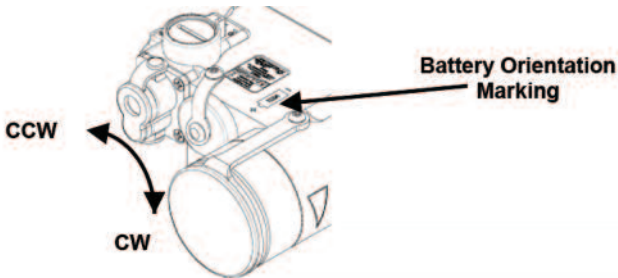

Figure 3-1 Battery Installation

3.2.b Activation Mode Selector Switch

NOTE

The DBAL-D² will not operate if the rotary switch is not precisely aligned with the marked switch position.

In extreme cold temperatures the switch may offer more resistance.

The Activation Mode Selector Switch is located on the center rear of the DBAL-D² housing (see Figure 3-2). The switch is used to select between the various modes of operation. The Activation Mode Selector Switch has seven positions. See Table 3-1.

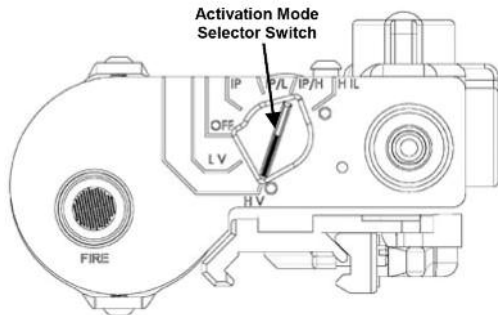

Figure 3-2 Activation Mode Selector Switch

Table 3-1 Activation and Mode Selector Switch Functions

Item #	Mode	Switch Position	Activation Method	Use
1	High Visible Pointer	H V	When Remote Cable Switch or Fire Button switch is depressed.	Used for pointing or aiming at close range in daylight or at longer range in low light conditions. DO NOT use for boresighting the weapon.
2	Low Visible Pointer	L V	When Remote Cable Switch or Fire Button switch is depressed.	Primarily used for boresighting the laser to the weapon in low light conditions or close quarter combat situations.
3	OFF	OFF	OFF	Not in use or in storage.
4	High IR Pointer	IP	When Remote Cable Switch or Fire Button switch is depressed.	Used for acquiring targets.
5	High IR Pointer/ Low IR LED illuminator	IP/L	When Remote Cable Switch or Fire Button switch is depressed.	Used for pointing and aiming indoors or outdoors at close range. The IR LED illuminator is used to provide illumination of shadowed areas.
6	High IR Pointer/ High IR LED illuminator	IP/H	When Remote Cable Switch or Fire Button switch is depressed.	Illuminates the target area and provides an aiming point to accurately engage the target.
7	High IR LED illuminator	H IL	When Remote Cable Switch or Fire Button switch is depressed.	Used for supplemental illumination of a shadowed area.

3.1.c Integrated Momentary Activation Switch

NOTE

Click sound is minimized by depressing the center of the switch.

The Integrated Momentary Activation Switch is located on the left rear of the DBAL-D² housing above the word FIRE (see Figure 3-3). Firmly pressing and holding the switch activates the DBAL-D² laser selected by the Activation Mode Selector Switch. When the switch is released, the selected laser turns off. Pressing the Integrated Momentary Activation Switch twice in rapid succession will activate the DBAL-D² in a continuous ON mode for 5 minutes. Pressing the Integrated Momentary Activation Switch once again will return the device to the momentary mode.

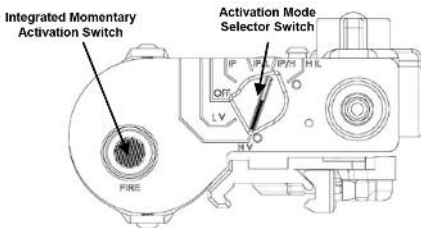

Figure 3-3 Integrated Momentary Activation Switch

If the unit is locked in continuous ON mode, rotation of the Integrated Momentary Activation Switch does not return the device to momentary mode unless the switch is moved through the OFF position. The 5 minute time out remains in effect.

3.1.d Activation Indicator/Low Battery Indicator.

A green LED is located on the rear housing at the bottom right of the Activation Mode Selector Switch (see Figure 3-4). When continuously ON, the LED indicates that the DBAL-D² is actively emitting laser or LED energy. If the LED is blinking, the battery is low and must be replaced.

When the Activation Mode Selector Switch is turned to an operating position, the LED will light up if either the Remote Cable Switch or Integrated Momentary Activation Switch is depressed, indicating that the device is ON. The LED will remain lit until the Integrated Momentary Activation Switch or Remote Cable Switch is released.

When the Remote Cable Switch or Integrated Momentary Activation Switch has been depressed twice in rapid succession, the LED will light up indicating that the unit is functioning in a constant ON mode. The LED will remain lit for 5 minutes or until Integrated Momentary Activation Switch or Remote Cable Switch is pressed once again to return the device to momentary activation.

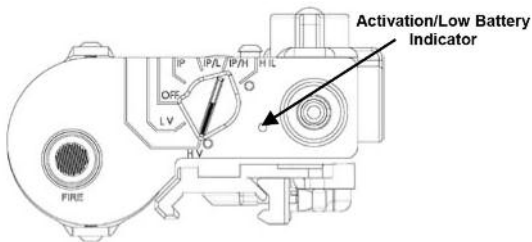

Figure 3-4 Activation LED

3.2.f Remote Cable Switch

CAUTION

DO NOT remove the Remote Cable Switch by pulling on the cable.

NOTE

When installing the Remote Cable Switch, gently twist the plug into the remote cable port.

The DBAL-D² Activation Mode Selector Switch must be turned to a mode setting in order to effectively use the Remote Cable Switch.

DBAL-D² will not operate if the rotary switches are not precisely aligned with the marked switch position.

The Remote Cable Switch plugs into the back of the DBAL-D² (see Figure 3-5). Depressing the Remote Cable Switch activates the DBAL-D² in the mode selected by the Activation Mode Selector Switch. When the Remote Cable Switch is released, the selected beam turns off.

In the Momentary Mode when the Remote Cable Switch has been pressed twice in rapid succession, DBAL-D² will activate in a constant ON mode for 5 minutes unless the Remote Cable Switch is pressed once again to return the device to momentary activation.

When the Remote Cable Switch is installed into the DBAL-D², it automatically locks in place. To remove it, pull back on the plug's sleeve.

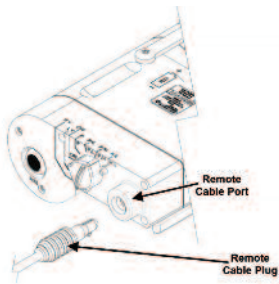

Figure 3-5 Installation of Remote Cable Switch

3.1.f Exit Port Covers

The DBAL-D² is supplied with a VIS POINT/IR POINT Exit Port Cover and an IR LED illuminator Exit Port Cover. The Exit Port Covers prevent laser energy emission when properly installed over the exit ports. The exit port covers are held in place by the retention studs located above and below each exit window. Figure 3-6 illustrates the Exit Port Covers.

Install the Exit Port Cover over the pointers and illuminator by gently pulling it forward until it may be moved into place over the laser Exit Port Lens. Align the step on the inside surface of the Exit Port cover with the exit port and press the cover firmly into place. When the DBAL-D² is not in use, the Exit Port Covers shall be installed over the lenses to prevent accidental emission of laser energy and to protect the Exit Port lenses.

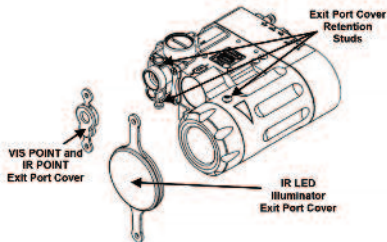

Figure 3-6 Exit Port Cover Installation

3.1.g IR LED Illuminator Focusing Knob

CAUTION

To prevent damage to the IR LED Illuminator Exit Port Cover, open the Exit Port Cover before turning the knob to adjust the focus.

NOTE

In extreme cold temperatures the illuminator focusing knob may offer more resistance. The illuminator focus knob direction of rotation and the corresponding beam size (2° to 30°) is indicated by the triangle on the side of the housing, refer to Figure 3-7.

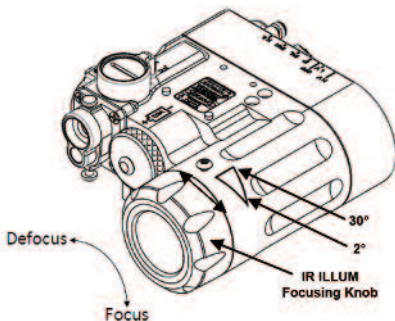

Figure 3-7 The IR LED Illuminator Focusing Knob

3.1.h Windage and Elevation Adjusters

NOTE

The windage and elevation adjusters may offer some resistance as you turn it in a CW direction from the factory neutral position. When the adjuster is harder to turn it has reached the maximum CW travel.

When the adjuster is at its maximum CW or CCW point of travel and is turned in the opposite direction the laser point may trace a small loop on the target. This is normal and does not indicate a failure condition.

A positive load is required on the adjustment mechanism when boresighting/zeroing the DBAL-D² for purposes of retaining the set alignment. See paragraph 3.4.

The adjuster knobs on the DBAL-D² may vary slightly in the force required to turn the adjusters. This is normal and does not indicate a failure condition. At the maximum CW or CCW travel the DBAL-D² lasers may not move a full 1cm per click, or may jump squares on the target. If this happens the DBAL-D² should be returned to its factory neutral preset as described in Section 3.5. DBAL-D² is for use on weapons where the MIL-STD-1913 rail is parallel with the bore of the weapon. In the factory neutral position the visible pointer/IR

pointer should project on the same side of the target as the laser is mounted and must fall within 1.5 mrad circle/10.2 cm of the bore at 25 meters. See Section 3.5.

The DBAL-D² is equipped with adjusters for tuning the visible and IR pointer for elevation and azimuth (see Figure 3-8 and Figure 3-9). Each adjuster click will move the laser point by 1 cm at 25 meters.

The visible pointer/IR pointer adjuster guards are marked with arrows and the letters U/D and R/L indicating the direction that the shot group will move if an adjuster is turned when the laser is mounted in the horizontal (top) position. The adjusters will move the visible pointer/IR pointer approximately 10" or 25 cm in each direction from the factory neutral preset position at 25 meters. See Paragraph 3.5.

The visible pointer and the IR pointer are adjusted using the same adjusters. Boresighting/zeroing the visible pointer will align the IR pointer and vice versa. For improved accuracy, always align the primary laser expected to be used on the mission.

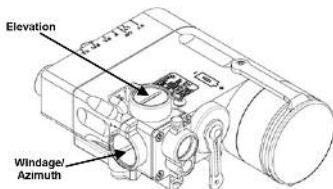

Figure 3-8 Boresight Windage and Elevation Adjusters for Aiming and Illumination Beams

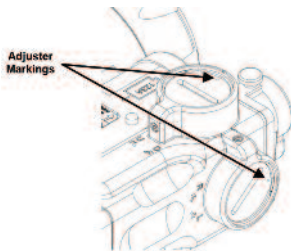

Figure 3-9 Adjuster Markings

3.1.i Visible Pointer and IR Pointer Adjustment

Table 3-2 indicates the direction of adjuster rotation and resultant shot group movement for zeroing the visible pointer or IR pointer to the weapon when the DBAL-D² is side-mounted.

Table 3-2 Adjuster Rotation and Shot Group Movement for the Visible Pointer and IR pointer (Side Mounted-Left)

ZEROING THE AIMING LASER	Adjuster Movement	Shot Group Movement
Side Adjuster Elevation (guard marked U/D)	CW CCW	Left Right
Top Adjuster Windage (guard marked R/L)	CW CCW	Up Down

When adjusting in a CCW direction, apply a positive load to the adjuster by turning an additional 1/4 turn (8 clicks) CCW, then make the final boresighting/zeroing adjustments by turning the adjusters in a CW direction. No positive load is required when adjustments are made in the CW direction.

CHAPTER III – SECTION II MOUNTING PROCEDURES

3.2 MOUNTING PROCEDURES

WARNING

Be sure the weapon is CLEAR and on SAFE before proceeding.

NOTE

The DBAL-D² may be placed at any position (forward and aft) on the rail that is convenient for the operator. If the DBAL-I² is removed from the rail, the operator must take note of the position at which it was zeroed, and return it to the same position in order to ensure that zero is retained. Tests have shown that accuracy is best when the DBAL-D² is mounted on the forward rails.

Failure to fully tighten the Quick Release Mount will cause zero retention problems. Insure that the base of the Quick Release Mount is fully seated on the MIL-STD-1913 rail with NO front or rear overhang.

An integrated Quick Release Mount is used to attach the DBAL-D² to weapons equipped with a MIL-STD-1913 rail. Place the device far enough back on the rail to allow for battery replacement without removal from the weapon. If removed, the DBAL-D² must be returned to the same position on the rail to retain zero.

The DBAL-D² may be mounted on the TOP, LEFT, or RIGHT rail using the Quick Release Mount. Open the Quick Release Mount so that it is perpendicular to the DBAL-D² housing. See Figure 3-10.

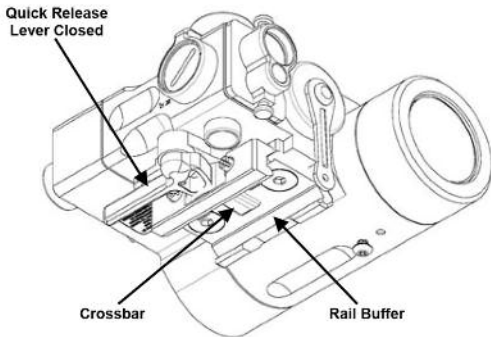

Figure 3-10 Quick Release Mount Configuration

Place the rail buffer against the left side of the MIL-STD-1913 rail and align the crossbar on the bottom of the mount with a slot on the rail. Push forward on the DBAL-D² so that the crossbar contacts the front of the slot on the MIL-STD-1913 rail. Move the Quick Release Lever arm so that it is parallel with the body of the laser housing. See Figure 3-10.

Install the Remote Cable Switch in a convenient location.

CHAPTER III – SECTION III BORESIGHTING/ZEROING PROCEDURES

This section provides boresighting/zeroing instructions using the AA Borelight System, Item No. 9090 on a 25-meter range.

WARNING

Be sure the weapon is CLEAR and on SAFE before proceeding.

3.3 PLACING A POSITIVE LOAD ON THE ADJUSTERS

CAUTION

DO NOT over-adjust the adjusters by forcing them beyond their end of travel.

NOTE

ALWAYS Boresight/Zero the DBAL-D² starting with the Adjuster marked D/U.

When moving the adjusters, make sure that the adjustment mechanism has engaged a detent and has not stopped between detents. Failure to properly engage a detent may impact accuracy as the laser may move when the weapon is fired.

Positive Load is required anytime an adjustment to visible pointer/IR pointer is made in a CCW direction. A Positive Load is not required when making a CW adjustment.

Positive Load is the controlled compression of the spring within the adjuster mechanism to insure the highest level of accuracy is maintained after the weapon is boresighted or zeroed.

When adjusting in a CCW direction, apply a positive load to the adjuster by turning an additional $\frac{1}{4}$ turn (8 clicks) CCW, then make the final boresight/zero adjustment by turning the adjuster CW. For example, to move the adjuster one (1) click CCW, turn the adjuster CCW 8 clicks and then turn it CW 7 clicks to the new position.

3.4 FACTORY NEUTRAL PRESET

CAUTION

DO NOT over-adjust the adjusters by forcing them beyond their end of travel.

NOTE

ALWAYS boresight/zero the DBAL-D² starting with the Adjuster marked U/D.

When moving the adjusters, make sure that the adjustment mechanism had engaged a detent and has not stopped between detents. Failure to properly engage a detent may adversely impact accuracy as the laser may move to the next detent when the weapon is fired.

The adjuster may offer some resistance as you turn it in a CW direction from the factory neutral position. When the adjuster is harder to turn it has reached the maximum CW travel.

The DBAL-D² is preset at the factory to a neutral position, see Figure 3-11. In the neutral position the laser beam is parallel to the bore of the weapon

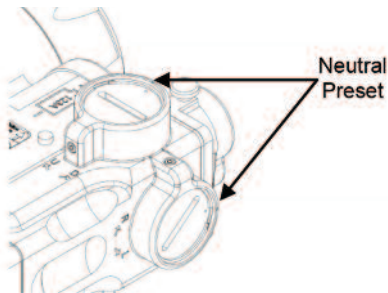

Figure 3-11 Neutral Preset

Table 3-4 Factory Neutral Preset

Adjuster	Instruction
Adjuster Guard marked U/D for the visible pointer and IR pointer	First, turn CW to end of travel. DO NOT force past mechanical stop. Next, turn CCW 1 1/4 turns. Finally, turn CW to align the dot on the adjuster with the dot on the adjuster guard.
Adjuster Guard marked R/L for the visible pointer and IR pointer	

3.5 BORESIGHT USING THE LASER BORELIGHT SYSTEM ZEROING

WARNING

NEVER boresight in the High Power mode of operation.

CAUTION

DO NOT over-adjust the adjusters by forcing them beyond their end of travel.

NOTE

The mission will dictate which aiming laser (visible pointer/ IR pointer) will be boresighted to achieve maximum accuracy.

A positive load is required on the adjustment mechanism when boresighting/zeroing the DBAL-D² for purposes of retaining the set alignment. See paragraph 3.4.

Always move the adjusters slowly, one click at a time, to prevent the adjuster from jumping detents.

In extreme cold temperatures, the adjusters may offer more resistance. The adjuster may offer some resistance as you turn it in a CW direction from the factory neutral position. When the adjuster is harder to turn, it has reached the maximum CW travel. When the adjuster is at its maximum CW or CCW point of travel and is turned in the opposite direction, the laser point may trace a small loop on the target. This is normal and does not indicate a failure condition.

The adjuster knobs on the DBAL-D² may vary slightly in the force required to turn the adjusters. This is normal and does not indicate a failure condition.

At the maximum CW or CCW travel, the DBAL-D² lasers may not move a full 1 cm per click at 25 meters, or may jump squares on the target. If this happens the DBAL-D² should be returned to its factory neutral preset as described in Section 3.5.

3.5.b Zeroing on a 25-Meter Range

This procedure is used to zero the DBAL-D². Each adjuster click moves the strike point by 1 cm on a 25-meter zeroing target. Refer to Figure 3-12 and Figure 3-13.

1. On a 25-meter zeroing target, mark the designated strike point and designated 4 cm/6 cm strike zone based on the weapon you are using.

2. Mount the target on an “E” silhouette or other suitable surface at 25 m.
3. Set the adjusters to their factory neutral position as described in Paragraph 3.5.
4. Activate the aiming laser (visible pointer or IR pointer) to be zeroed by rotating the Activation Mode Selector Switch to the desired position. Press the Integrated Momentary Activation Switch or the Remote Cable Switch twice in rapid succession to activate the laser continuously. When aligning the IR pointer, leave the IR LED ILLUM Exit Port Cover in place. Aim center mass of the target until the aiming laser disappears through the 4 cm cut out.
5. Fire a 3-round shot group and note the center of the shot group relative to the designated strike zone.
6. Adjust the aiming beam adjusters to move the center of the shot group to the designated strike zone.
7. Repeat steps 5 and 6 until the shot group falls within the strike zone.
8. When firing the M16, M4 series series of weapons, when 5 out of 6 consecutive rounds are in the designated 4cm strike zone you are zeroed. When firing the M240 and M249 series of weapons, when 5 out of 12 non-consecutive rounds are within a 6cm square, the weapon is zeroed.
9. Rotate the DBAL-D² Activation Mode Selector Switch to OFF.

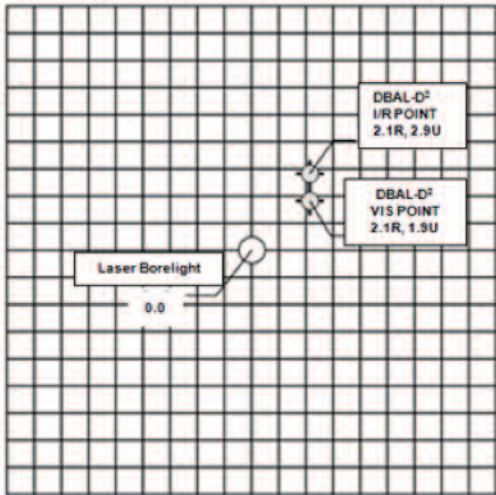

Zero Target Data for M4/M16A4

25m Boresight Target for 300m Zero

1. Stabilize Weapon
2. Align Laser Borelight on its dot.
3. Adjust DBAL-D2 until aiming laser is centered on the dot – cross hair.
4. Apply a positive load to the adjusters.

Figure 3-12 25-meter Boresight Target

25 METER ZEROING TARGET
M16A2/M16A4

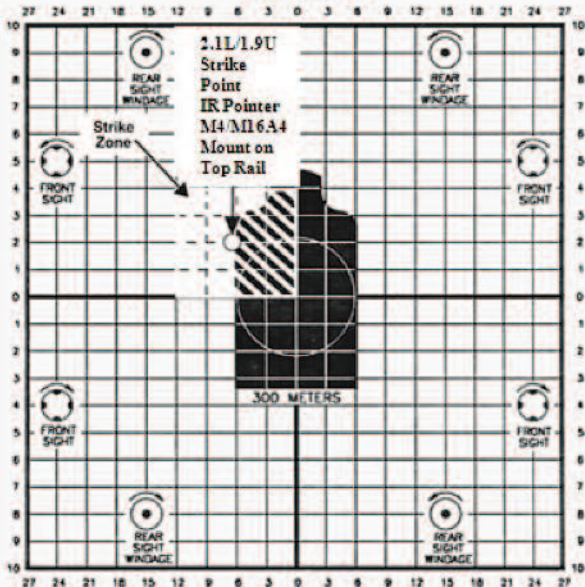

Figure 3-13 25-meter Zeroing Target

CHAPTER IV – SECTION I PREVENTIVE MAINTENANCE CHECKS

4.1 GENERAL

NOTE

Perform functional tests in the order listed in Table 4-1. Operating Procedures are detailed in Chapter III, Section I.

Functional testing of the DBAL-D² to ensure proper operation should be performed in a dark room or area away from light. Viewing of IR beams must be performed with a NVD.

4.1.a Warnings and Cautions

Always observe the WARNINGS and CAUTIONS appearing in the table.

4.1.b Explanation of Table Entries

1. Item Number

Numbers in this column are for reference. Item numbers also appear in the order that you must perform the checks and services listed.

2. Interval

This column tells you when you must do the procedure in the procedure column. BEFORE (B) PROCEDURES must be done before you operate or use the equipment. DURING (D) PROCEDURES must be done during the time you are

operating or using the equipment. AFTER (A) PROCEDURES must be done immediately after you have operated or used the equipment.

3. Item to Check/Service

This column provides the item to be checked or serviced.

4. Procedure

This column gives the procedure you must do to check the item.

5. Not Fully Mission Capable If

Information in this column tells you what faults will keep your equipment from being capable of performing its primary mission.

Be sure to observe all special information and notes that appear in your table.

Table 4-1 Preventive Maintenance Checks and Services

Item No.	Interval	Item to Check/Service	Procedure	Not Fully Mission Capable If:
1	B/D/A	DBAL-D ² Exterior	-Check housing for separation between the front and the rear section of the housing, missing screws switch knobs, and azimuth and elevation adjuster covers.	A gap appears between the front and the rear section of the housing, missing switch knob, or adjuster covers.
WARNING: DO NOT STARE DIRECTLY INTO INFRARED LIGHT BEAM				
2	B/A	Exit Port Covers	-Check for broken or missing covers, exit port cover retention studs. -Move the Exit Port Covers to the open position.	

Table 4-1 Preventive Maintenance Checks and Services

Item No.	Interval	Item to Check/Service	Procedure	Not Fully Mission Capable If:
3	B/A	Exit Port Lens	-Check for cracked, dirty or broken lenses or missing ILLUM focusing adjustment.	-If cracked or missing lens or missing ILLUM focusing knob.
4	B/A	Windage/Elevation Adjusters	-Check for broken, missing or stripped Adjusters.	-Adjusters broken, missing or stripped or laser fails to move.
5	B/D/A	Remote Cable Port	-Check for mud or dirt and clean as needed.	
6	B/A	Battery Compartment	-Check for corrosion, presence of O-ring, spring, battery cap lanyard. Inspect threads for dirt or damage.	-Corroded or broken contacts.
7	B/D/A	Quick Release Mount	-Check attachment to housing, broken, missing parts. -Inspect rail clamp, crossbar and mount base for dirt and corrosion. -If laser is loose on the rail: Move to a different position on the rail; Move to a different rail on weapon; Replace the rail on weapon.	-Quick release mount loose, missing parts or broken.

Table 4-1 Preventive Maintenance Checks and Services

Item No.	Interval	Item to Check/Service	Procedure	Not Fully Mission Capable If:
8	B/A	Battery Compartment O-Ring	-Check O-ring for cuts, cracks. -Lubricate as needed.	-Cracked or cut; may cause leakage into unit.
9	B/A	Activation Mode Selector Switch and Integrated Momentary Activation Switch	-Select LV using the Activation Mode Selector Switch. -Select FIRE and observe the beam spot on wall. -Repeat for each laser activation position.	-Activation Mode Selector Switch inoperative with the visible pointer, IR pointer, or IR LED illuminator beam spot not visible.
10	B	Boresight Alignment	-Confirm that the IR Pointer or visible pointer is boresighted/zeroed on the weapon on which it will be mounted. -Check to make sure that the visible pointer/ IR pointer projects on the same side of the target as the laser is mounted and falls within 1.5mrad circle/10.2cm of the bore at 25 meters.	-Cannot be zeroed or boresighted to weapon.
11	B/D/A	LED Status Indicator	-Observe green LED is lit when lasing.	-Indicator is flashing designating low battery.

Table 4-1 Preventive Maintenance Checks and Services

Item No.	Interval	Item to Check/Service	Procedure	Not Fully Mission Capable If:
12	B	Exit Port Covers	-Close exit port covers and press into place. -Activate visible laser. -Make sure no light is being emitted from around the cover.	
13	A	Battery	-Remove battery.	-No, low or corroded battery.

CHAPTER IV – SECTION II TROUBLESHOOTING

4.2 GENERAL

The purpose of troubleshooting is to systematically search and identify the source of a problem. The most frequent equipment malfunctions, probable causes and corrective actions for the DBAL-D² are listed in Table 4-2. Perform the tests, inspections and corrective actions in the order they are listed. This manual does not list all malfunctions, tests, inspections, or corrective actions that may occur.

Table 4-1 Preventive Maintenance Checks and Services

Malfunction	Test / Inspection	Corrective Action	Ref. Para.
1. POINT/ILLUM beams fail to come on or stay on.	a. Ensure Activation switch is on and Mode Selector Switch is in proper position.	-Properly align switch.	3.2.b
	b. Verify Exit Port Cover is removed and that the Exit Port Lens is not obscured by mud/dirt.	-Remove Exit Port Covers. -Clean POINTER/ILLUM Exit Port Lenses.	4.4.e
	c. Verify battery installation.	-Tighten battery cap. -Install new battery.	3.2.a
	d. Inspect battery cap for damage or corrosion.	-Notify Unit Maintenance.	5.2.a
	e. Inspect battery contact spring and Mode Selector Switch is in the battery compartment for damage or corrosion.	-Notify Unit Maintenance.	5.2.a

Table 4-1 Preventive Maintenance Checks and Services

Malfunction	Test / Inspection	Corrective Action	Ref. Para.
1. POINT/ILLUM beams fail to come on or stay on.	f. Possible internal failure.	-Notify Unit Maintenance.	5.2.a
2. POINT/ILLUM beams have become weak (not as bright).	a. Verify Exit Port Cover is removed and that Exit Port Lens is not obscured by mud / dirt.	-Remove Exit Port Cover. -Clean POINTER & ILLUM Exit Port Lenses.	4.4.e
	b. Verify proper battery installation.	-Tighten battery cap. -Install new battery.	3.2.a --
	c. Verify Exit Port Lens is not scratched or pitted.	-Notify Unit Maintenance.	5.2.a
	d. Verify battery installation.	-Install new battery. -Tighten battery cap.	3.2.a
3. Low Battery Indicator Light remains on when new battery is installed.	a. Inspect battery compartment for corrosion.	-Clean battery compartment.	4.3.c
	b. Inspect Battery Cap contact for corrosion.	-Clean battery cap.	4.3.d
	c. Inspect battery cap and housing threads for contamination.	-Clean battery cap and housing threads.	4.3.e
4. POINTER/ILLUM beams DO NOT move.	a. Verify adjuster function.	-Clean as required -Notify Unit Maintenance.	4.3.a
5. ILLUM knob turns, but beam does not change.	a. Verify knob is free of mud and dirt.	-Clean as required -Notify Unit Maintenance.	4.3.a

Table 4-1 Preventive Maintenance Checks and Services

Malfunction	Test / Inspection	Corrective Action	Ref. Para.
6. Remote Cable Switch inoperable, but Integrated Momentary Activation Switch functions.	a. Verify Remote Cable Switch plug is fully seated.	-Reconnect plug.	3.2.e
	b. Verify Remote Cable Port is free of mud / dirt.	-Flush with water.	4.3.g
	c. Inspect Remote Cable Plug Contacts.	-Clean as needed.	4.3.g
	d. Verify function of Remote Cable Switch.	-Notify Unit Maintenance.	5.2.a
7. POINTER beam cannot be zeroed to weapon.	a. Verify Quick Release Mount is properly positioned/secured to weapon.	-Properly position and secure.	3.3
	b. If laser is loose on rail:	-Move to different position on rail. -Move to different rail on weapon. -Replace rail on weapon.	3.3
	c. Inspect mount base for corrosion or dirt.	-Clean as required. -Notify Unit Maintenance.	4.3.a
	d. Verify DBAL-D ² is properly secured to Quick Release Mount.	-Notify Unit Maintenance.	5.2.a
	e. Verify Quick Release Mount is not damaged.	-Notify Unit Maintenance.	5.2.a

CHAPTER IV – SECTION III OPERATOR MAINTENANCE

4.3 GENERAL

WARNING

DO NOT store the DBAL-D² with the battery installed.

CAUTION

The use of gun cleaning agents that contain perchloroethylene or methylene chloride may permanently damage the DBAL-D² system.

The DBAL-D² is a rugged, compact laser device that is designed to operate in severe environments. The exterior housing is made of aircraft grade aluminum and the outer components are made of chemically resistant materials that will not be harmed by substances normally encountered. User maintenance is limited to the inspection and cleaning of the DBAL-D² external surfaces, replacement of the battery before each use and removal of the battery after each use.

4.3.a External Cleaning

Clean the exterior of the DBAL-D² by flushing with water and wiping with a clean, soft cloth. Cleaning should be done whenever the DBAL-D² becomes dirty or after exposure to salt water.

4.3.b Exit Port Lens Cleaning

To clean the pointer and illuminator Exit Port Lenses, wipe clean using a soft cloth or disposable applicator dampened with water.

4.3.c Battery Compartment

Before each use, inspect the battery and battery compartment for dirt, dust, or corrosion. If dirty, clean using a soft cloth or disposable applicator.

4.3.d Battery Cap

Before each use, inspect the battery cap for dirt, dust or corrosion. If dirty, clean using a soft cloth or disposable applicator. Prior to water operations or emersion, inspect the O-ring seals in the battery cap to make sure they are free of sand or dirt particles. If the O-ring becomes cut, nicked or dried out, it should be replaced. If the battery cap is bent or scratched in the O-ring seating area, it should be replaced.

4.3.e Battery Compartment and Housing Threads

Inspect threading on the battery cap and housing for contamination. If the threading appears to be oily or dirty, clean with Isopropyl Alcohol using a soft, clean cloth.

4.3.f IR LED illuminator

Prior to water operations or emersion, make sure that the IR LED Illuminator Focusing Knob has been tightened in a CW direction so that it is seated on the housing. This will fully compress the internal O-rings to prevent the possibility of water infiltrating the housing.

4.3.g Battery Removal and Replacement

Refer to Chapter III, Paragraph 3.2.a for Battery Installation procedures. No special tools or equipment are required to replace the battery.

Unscrew the battery cap in a CCW direction. Remove and properly discard the spent battery. Inspect the battery compartment for dirt, moisture and corrosion. Install the battery as indicated by the marking on the DBAL-D² housing. Reinstall the battery cap and hand tighten in a CW direction.

4.3.h Remote Cable Port

Before each use, inspect the remote cable port for dirt, dust, or corrosion. Thoroughly clean the receptacle by flushing with water, then wipe with a soft cloth or disposable applicator.

4.4 REMOVAL AND REPLACEMENT OF PARTS

Maintenance is authorized for the removal and replacement of a limited number of assemblies. Special tools or equipment are not required for maintaining the DBAL-D².

4.4.a Remove and Install Battery

See Chapter III, Paragraph 3.2.a for procedures. Figure 4-1 depicts the removal and installation of the battery.

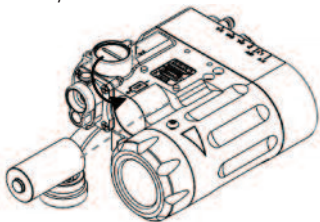

Figure 4-1 Battery Removal and Installation

4.4.b Remove and Replace Battery Cap

NOTE

Remove the Exit Port Cover Retaining Strap first and then remove the Battery Cap Retaining Strap.

Install the Battery Cap Retaining Strap below the Exit Port Cover Retaining Strap below the VIS Exit Port. If necessary, remove the bottom Exit Port Cover strap from the IR LED Illuminator Exit Port Cover then install the Battery Cap Retaining Strap.

To remove, stretch the end of the Retaining Strap over the stud on the Battery Cap then unscrew the battery cap.

To install, stretch the end of the retaining strap over the stud located on the battery cap. Figure 4-2 depicts the removal and replacement of the battery cap.

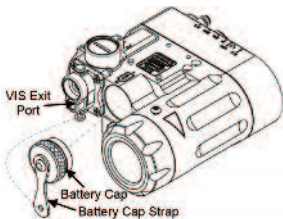

Figure 4-2 Remove and Replace Battery Cap

4.4.c Removal and Replacement of Battery Cap Retaining Strap

NOTE

To install, stretch the end of the retaining strap over the stud located on the battery cap. Stretch the other end of the retaining strap over the stud located directly below the VIS Exit Port.

To remove, stretch the end of the Retaining Strap over the stud on the Battery Cap then stretch the other end over the stud located directly below the VIS Exit Port. Figure 4-3 depicts the removal and replacement of the battery cap retaining strap.

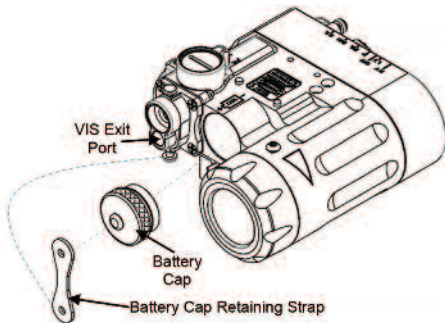

Figure 4-3 Remove and Replace Battery Cap Retaining Strap

4.4.d Remove and Replace Battery Cap O-ring

NOTE

NEVER use a sharp or metal object to remove O-rings as they may damage the O-ring or the O-ring groove contact surface. Inspect the O-ring for nicks, cracks, cuts or abrasion. Also check to make sure that it feels soft. If damaged, replace the O-ring.

To remove, pull the O-ring out of the groove at the base of the threaded portion of the battery cap. Install the new O-ring by gently pulling it onto the battery cap so that it fits in the groove located at the base of the threaded portion of the battery cap. Figure 4-4 depicts the removal and replacement of the battery cap O-ring.

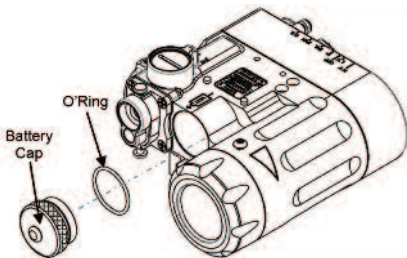

Figure 4-4 Remove and Replace Battery Cap O-Ring

4.4.e Removal and Replacement of Exit Port Cover Retaining Straps

To remove the top Exit Port Cover, pull on the loose end of the Exit Port Cover retaining strap and stretch it over the top stud. Repeat the procedure to remove the bottom Exit Port Cover retaining strap from the DBAL-D².

To replace the Exit Port Cover Retaining Straps, stretch the end of the retaining strap over the retaining stud located on the bottom of the housing. Repeat the procedure by stretching the loose end of the retaining strap over the stud located on the top of the housing. Figure 4-5 depicts the removal and replacement of the Exit Port cover and retaining straps.

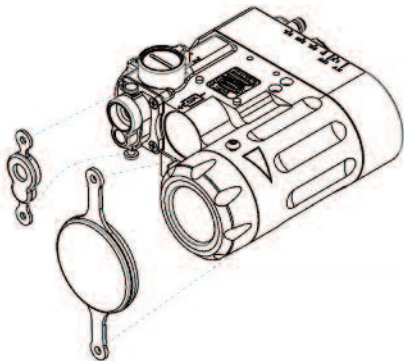

Figure 4-5 Remove and Replace Exit Port Cover Retaining Straps

CHAPTER V – SERVICE/PACKING AND UNPACKING

5.1 Steiner 3-Year Laser Device Warranty

On all laser devices, Steiner offers a 3-Year Limited Warranty from the date of purchase that covers all laser, optical and electronic components, materials and workmanship. All warranties are void if the serial number or manufacturer's labels affixed to the product have been removed, or if products have been abused, misused, modified, neglected or have been disassembled prior to return to the manufacturer.

5.2 Warranty or Repair Service

5.2.a If you require warranty or repair service please contact Steiner Optik, and we will determine the best way to fix your device. For more information, email laserlightsinfo@steiner-optics.com or call 888-288-7747.

5.2.b To assist the Customer Service with determining if the item is repairable, please provide the following information:

1. Serial Number of the defective item.
2. Thorough description of the malfunction, defect or damage.
3. An explanation as to how the malfunction, defect or damage occurred, if known.

If Steiner determines that the item is under warranty or should be returned for repair, a Return Material Authorization (RMA) number will be provided.

5.2.c When returning the DBAL-D² for service or repair, the following procedures should be followed to prevent any additional damage:

1. Be sure that the DBAL-D² is free of all contaminants such as dirt or any other foreign material.
2. Remove the battery.
3. Place the Exit Port Covers over each of the lenses.
4. Place the DBAL-D² in the Shipping Case or Carrying Case if available. If the Shipping Case is not available, individually package each DBAL-D² unit being returned in a suitable container.

5.2.d Place the DBAL-D² and a copy of the test report or detailed description of the failure in a suitable packing/shipping container. Mark the package with the RMA number. Ship by the fastest, traceable, prepaid means to the address provided by Steiner Customer Service.

APPENDIX A REPAIR PARTS

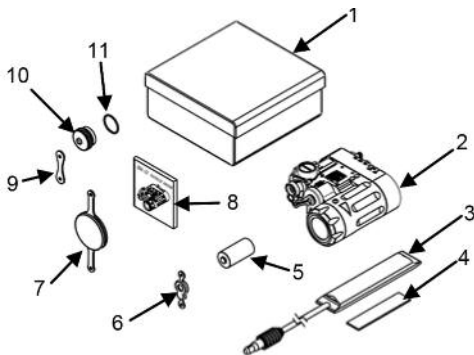

Figure 1 Repair Parts



STEINER-OPTIK

331 East 8th Street • Greeley, CO 80631

Tel: (888) 228-7747 • Fax: (970) 356-8702

Customer Service: laserlightsinfo@steiner-optics.com

steiner-optics.com