

# OTAL-A



## Technical Manual

**OFFSET TACTICAL AIMING LASER-ADVANCED**  
VISIBLE LASER POINTER

**STEINER**   
Nothing Escapes You

# TABLE OF CONTENTS

---

	Page
SAFETY SUMMARY .....	2
HOW TO USE THIS MANUAL .....	7
GENERAL INFORMATION .....	8
EQUIPMENT DESCRIPTION .....	12
SECTION I OPERATING INSTRUCTIONS .....	18
SECTION II MOUNTING PROCEDURES .....	33
SECTION III BORESIGHTING/ZEROING PROCEDURES.....	35
SECTION I OPERATOR PREVENTIVE MAINTENANCE CHECKS .....	43
SECTION II OPERATOR TROUBLESHOOTING .....	48
SECTION III OPERATOR MAINTENANCE.....	51
SECTION I UNIT TROUBLESHOOTING .....	55
SECTION II UNIT MAINTENANCE .....	58
SECTION III SERVICE/PACKING AND UNPACKING.....	66
REPAIR PARTS .....	68

# SAFETY SUMMARY

---

## WARNING

**INVISIBLE LASER RADIATION  
AVOID DIRECT EXPOSURE TO THE BEAM**

**VISIBLE GREEN POINTER (CLASS IIIA)  
LASER WAVELENGTH: GREEN - 532 nm  
OUTPUT: <5 mW**

- DO NOT stare into the laser beam.
- DO NOT look into the laser beam through binoculars or telescopes.
- DO NOT point the laser beam at mirror-like surfaces.
- DO NOT shine the laser beam into other individual's eyes.



## Safety Data

<b>PART NO.</b>	<b>LASER</b>	<b>Power Output</b>	<b>SAFETY CLASS</b>	<b>NOHD (m) Unaided</b>
ITAL-A	Vis Green High Power	<5 mW	IIIa	77
OTAL-A	Vis Green High Power	<5 mW	IIIa	77

### **DEFINITION OF THE FOLLOWING ALERTS THROUGHOUT THIS MANUAL:**

#### **WARNING**

Identifies a clear danger to the person doing that procedure.

#### **CAUTION**

Identifies risk of damage to the equipment.

#### **NOTE**

Used to highlight essential procedures, conditions, statements, or convey important instructional data to the user.

## **WARNING**

Be sure the weapon is CLEAR and on SAFE before proceeding.

## **WARNING**

The High Power Modes are blocked with a safety screw.

## **WARNING**

In order to make the laser operate in the High Power modes of operation the blue safety screw must be removed from the back of the unit. The Unit Commander must direct this action.

## **WARNING**

Make sure the Activation Selector Switch is in the OFF position before inspecting the laser Exit Port Lens.

## **WARNING**

If the Activation Selector Switch is not in the OFF position, the laser can be inadvertently activated by depressing the fire button on the top of the housing.

## **WARNING**

The laser is powered by one CR 123A Lithium Magnesium Dioxide (Li/MnO<sub>2</sub>) Battery. The following safety precautions apply when handling lithium batteries.

- DO NOT short circuit, puncture, or disassemble
- DO NOT attempt to recharge
- DO NOT mix brands of batteries

- NEVER dispose of lithium batteries in a fire, or in any way expose lithium batteries to excessive heat
- Batteries may explode if disassembled, crushed, recharged, or exposed to high temperatures
- Avoid mechanical or electrical abuse
- Prior to use, inspect all batteries for cracks, leakage, or bulging
- NEVER install a defective battery
- DO NOT install battery incorrectly
- Store at room temperature
- DO NOT store with the battery installed

### **WARNING**

If a laser borelight is used to boresight the laser, be sure to remove the borelight from the weapon prior to firing.

### **WARNING**

NEVER boresight in the High Power mode of operation.

**CAUTION**

DO NOT over-adjust the laser adjusters by forcing them beyond their end of travel.

**CAUTION**

DO NOT over tighten the Safety Screw when installing it into the laser housing as you may strip the housing threads.

**CAUTION**

Use ONLY authorized cleaning supplies on the laser or permanent damage may occur.

**CAUTION**

DO NOT remove the Remote Cable Switch by pulling on the cable.

# HOW TO USE THIS MANUAL

---

## Usage

You must familiarize yourself with the entire manual before operating the equipment. Read the complete maintenance task before performing maintenance and follow all **WARNINGS, CAUTIONS** and **NOTES**.

## Manual Overview

This manual contains sections for Operating and Maintaining the ITAL-A Green and OTAL-A Green Laser Pointers with Modulation Mode.

## Appendix A Repair Parts

## CHAPTER 1—GENERAL INFORMATION

---



**Figure 1-1 OTAL-A in Use**



**Figure 1-2 ITAL-A in Use**

## **1.1 GENERAL INFORMATION**

### **1.1.a Type of Manual:**

Operator and Field Maintenance Manual.

### **1.1.b Equipment Name:**

ITAL-A, INLINE TACTICAL AIMING LASER-ADVANCED

OTAL-A, OFFSET TACTICAL AIMING LASER-ADVANCED

### **1.1.c Purpose of Equipment:**

For precise aiming and pointing using the Visible Pointer (VIS POINT) or to send a warning signal before escalation of force occurs using the Modulation Mode.

## **1.2 REPORTING EQUIPMENT IMPROVEMENT RECOMMENDATIONS**

If your equipment needs improvement, let us know. Mail your comments to Steiner-Optik, 331 E. 8th St., Greeley, CO 80631 or email: [laserlightsinfo@steiner-optics.com](mailto:laserlightsinfo@steiner-optics.com)

## **1.3 Steiner 3-Year Laser Device Warranty**

On all laser devices, Steiner offers a 3-Year Limited Warranty from the date of purchase that covers all laser, optical and electronic components, materials and workmanship. All warranties are void if the serial number or manufacturer's labels affixed to the product have been removed, or if products have been abused, misused, modified, neglected or have been disassembled prior to return to the manufacturer.

## 1.4 CROSS REFERENCES

### Common Name

Allen Wrench

Battery

Battery Cap

Gasket

Lens Cover

Neoprene Jack Plug

Paddle Switch

Pattern Generator

Safety Screw

Shipping Case

Tape Fastener Hook

Tape Fastener Loop

Technical Manual

### Official Name

Socket Head Screw Key

CR 123A

Battery Box Cover

O-Ring

Exit Port Cover

Plug Assembly

Remote Cable Switch

Optical Instrument Reticule

Electrical Dial-Knob Lock

Textile Bag

Fastener, Hook Tape

Fastener, Loop Tape

Operator and Field Maintenance Manual

## 1.5 LIST OF ABBREVIATIONS

C	Celsius (Centigrade)	mm	Millimeter
CCW	Counter-clockwise	mrad	Milliradians
cm	Centimeters	mW	Milliwatts
CTA	Common Table of Allowance	nm	Nanometers
CW	Clockwise	No	Number
EA	Each	NOHD	Nominal Ocular Hazard Distance
F	Fahrenheit	NSN	National Stock Number
HI	High	NVD	Night Vision Device
ILLUM	Illuminator	O.D.	Optical Density
in	Inches	OIR	Optical Instrument Reticle
IR	Infrared	Para	Paragraph
LBS	Laser Borelight System	PWR	Power
LED	Light Emitting Diode	QTY	Quantity
LO	Low	RAS	Rail Adapter System
m	Meter	RMA	Return Material Authorization
Max	Maximum	SR	Service Representative
Mfr	Manufacturer	TM	Technical Manual
Min	Minimum	VIS	Visible
MOM	Momentary		

## **CHAPTER 2 – EQUIPMENT DESCRIPTION**

---

### **2.1 SYSTEM DESCRIPTION**

The ITAL-A and OTAL-A are Class IIIa laser devices featuring a visible laser pointer (VIS POINT) and Modulation Mode. The laser can be operated in either low power (LOW), or high power (HI) settings. A Safety Screw, installed in the rear of the housing, prevents the operator from accessing the non-eye safe, HI power mode of operation.

The laser can be used as a handheld pointer or can be weapon mounted using the Quick Release Mount. In the weapon mounted mode, the laser can be used to accurately direct fire (HI and LOW modes) or as a warning device (MOD mode).

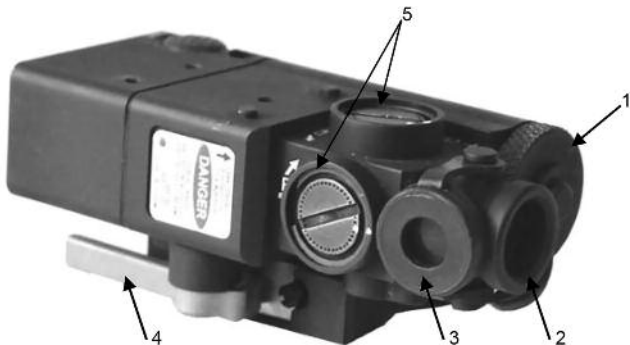

**Figure 2-1 Features**

<b>ITEM</b>	<b>DESCRIPTION</b>
1	Battery Cap and Compartment
2	Laser Exit Port
3	Laser Exit Port Cover
4	Quick Release Mount
5	Boresight Adjusters

## 2.2 GENERAL CHARACTERISTICS

**Table 2.2 Weight, Dimensions, and Performance**

### **WEIGHT**

(with one battery, 3-volt CR 123A)	6 oz / 170 grams
------------------------------------	------------------

### **DIMENSIONS**

Length	3.8 in. / 9.7 cm
--------	------------------

Width	1.8 in. / 4.6 cm
-------	------------------

Height (including mounting bracket)	1.45 in. / 3.7 cm
-------------------------------------	-------------------

### **PERFORMANCE**

#### **Laser Wavelength**

GREEN VIS POINT	532 nm
-----------------	--------

#### **Output Power (Hi Power)**

GREEN VIS POINT	<5 mW
-----------------	-------

Battery Life Up to 5 hours

#### **Beam Divergence**

GREEN VIS POINT	<0.8 mRad
-----------------	-----------

### **LASER RANGE**

#### **(STARLIGHT CONDITIONS)**

GREEN VIS POINT	750 m
-----------------	-------

## 2.3 DESCRIPTION OF MAJOR COMPONENTS

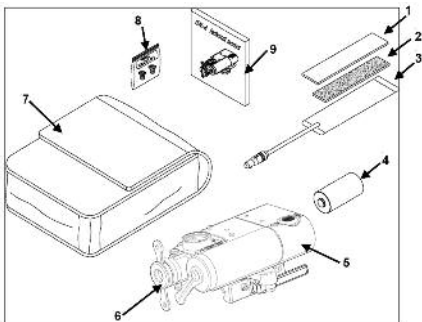

**Fig. 2-2 Major Components**

<b>ITEM</b>	<b>DESCRIPTION</b>
1	Tape Fastener Loop 5/8" (Black)
2	Tape Fastener Hook 1/2" (attached to remote cable switch) (Black)
3	Remote Cable Switch, HI Pressure MOM Remote, 7"
4	Battery, CR 123A
5	Laser Assembly
6	Exit Port Cover (installed)
7	Shipping Pouch
8	Screws for Optional Subminiature Red Dot Sight (sold separately)
9	Operator and Field Maintenance Manual

### **2.3.a Tape Fastener Loop**

The Tape Fastener Loop is provided to secure the Remote Cable Switch to the weapon in a position convenient to the soldier.

### **2.3.b Tape Fastener Hook**

The Tape Fastener Hook is pre-attached by the manufacturer to the pressure pad switch.

### **2.3.c Remote Cable Switch**

The 7-inch Remote Cable Switch allows the user to activate the laser in a momentary (MOM) fashion by depressing the pressure pad once. Pressing the pressure pad twice in rapid succession will activate the laser continuously for 5 minutes. Pressing the pressure pad again will return the unit to momentary activation. The pressure pad provides a tactile (silent) click that indicates when the switch has been activated. The Remote Cable Switch has a hook strip fastener attached to the switch.

### **2.3.d Battery**

The laser is powered by one CR 123A Lithium Magnesium Dioxide (Li/MnO<sub>2</sub>) Battery. The following safety precautions apply when handling lithium batteries.

- DO NOT short circuit, puncture, or disassemble
- DO NOT attempt to recharge
- DO NOT mix brands of batteries

- NEVER dispose of lithium batteries in a fire or in any way expose lithium batteries to excessive heat
- Batteries may explode if disassembled, crushed, recharged or exposed to high temperatures
- Avoid mechanical or electrical abuse
- Prior to use, inspect all batteries for cracks, leakage, or bulging
- NEVER install a defective battery in the laser
- Do not install incorrectly
- Store at room temperature
- DO NOT store the laser with the battery installed

One CR 123A battery is used to power the laser. The use of a high quality, lithium battery is recommended.

### **2.3.e Laser Assembly**

The device provides a VIS POINT. The device is used for aiming, signaling, command and control.

### **2.3.f Shipping Case**

The laser is provided with a Shipping Case intended for initial delivery only.

### **2.3.h Operator and Field Maintenance Manual**

The Operator and Field Maintenance Manual provides safety information, equipment information, operating instructions, mounting procedures, zeroing procedures, and maintenance procedures.

## CHAPTER III – SECTION I OPERATING INSTRUCTIONS

---

### 3.2 CONTROLS AND INDICATORS

#### 3.2.a Battery Installation

The laser is powered by one CR 123A Lithium Magnesium Dioxide (Li/MnO<sub>2</sub>) Battery. The following safety precautions apply when handling lithium batteries.

- DO NOT short circuit, puncture, or disassemble
- DO NOT attempt to recharge
- DO NOT mix brands of batteries
- NEVER dispose of lithium batteries in a fire or in any way expose lithium batteries to excessive heat
- Batteries may explode if disassembled, crushed, recharged or exposed to high temperatures
- Avoid mechanical or electrical abuse
- Prior to use, inspect all batteries for cracks, leakage, or bulging
- NEVER install a defective battery in the laser
- Do not install incorrectly
- Store at room temperature
- DO NOT store the laser with the battery installed

## **NOTE**

Loss or removal of the O-ring from the battery cap may allow water to enter the device.

Unscrew the battery cap in a CW direction. Remove and properly discard the spent battery. Inspect the battery compartment for dirt, moisture and corrosion. Clean the battery compartment as needed (refer to Paragraph 4.3.c). Inspect the O-ring seal on the battery cap to make sure it is free of sand and dirt particles and that it has not been damaged (see Paragraph 4.3.d). Install the battery as indicated by the marking on the OTAL-A/ITAL-A housing. Reinstall the battery cap and hand tighten in a CCW direction.

Install the battery by unscrewing the battery cap in a CCW direction. Inspect battery compartment for dirt, moisture and corrosion. Clean battery compartment as needed (see Paragraph 4.3.c). Inspect O-ring seal on the battery cap to make sure it is free of sand and dirt particles and that it has not been damaged (see Paragraph 4.3.d). Install the battery as indicated by the marking on the laser housing. Reinstall battery cap and hand tighten in a CW direction.

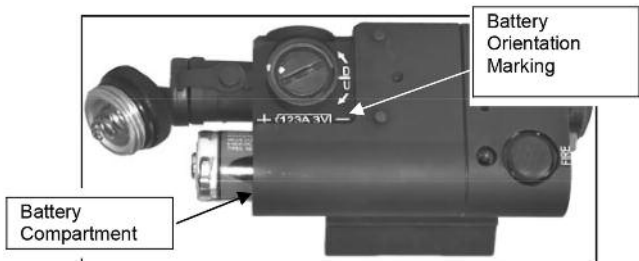

**Figure 3-1 Battery Installation**

### **3.2.b Activation Mode Selector Switch**

#### **WARNING**

The High Power Modes of operation are blocked with a blue Safety Screw.

#### **NOTE**

The laser will not operate if the rotary switch is not aligned with the marked switch position.

In extreme cold temperatures the switch may offer more resistance.

The Activation Mode Selector Switch is located on the left rear of the laser housing. It is used to select between the various modes of operation when the Remote Cable Switch or the Integrated Momentary Activation Switch is depressed. The Activation Mode Selector Switch has four (4) positions. See Table 3-2.

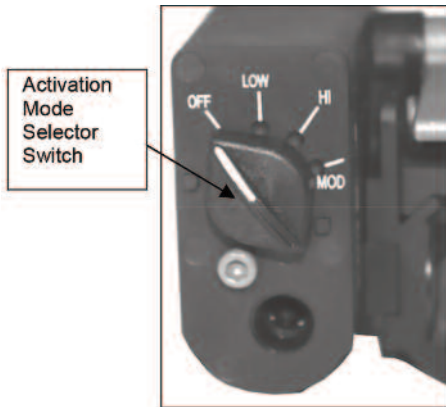

**Figure 3-2 Activation Mode Selector Switch**

**Table 3-1 Activation and Mode Selector Switch Functions**

<b>Switch Position Clockwise from the Left</b>	<b>Marking</b>	<b>Use</b>	<b>Remarks</b>
1	OFF	OFF	The laser will not operate
2	LOW	The laser is activated when the Remote Cable Switch or Integrated Momentary Activation switch is depressed.	Primarily used for bore sighting the laser to the weapon and for close range pointing or illumination.
3	HI	The laser is activated at its highest output when the Remote Cable Switch or Integrated Momentary Activation switch is depressed.	Primarily used for long range combat operations.
4	MOD	Modulation Mode—Activates eight (8) strobing laser pulses per second when the Remote Cable Switch or Integrated Momentary Activation switch is depressed.	Used to send a warning signal before escalation of force occurs.

### 3.2.c Safety Screw

To operate the OTAL-A/ITAL-A in the High Power modes, the blue Safety Screw must be removed from the back of the unit. The Armorer will remove and store the Safety Screw.

#### CAUTION

DO NOT over tighten the Safety Screw when installing it into the housing as you may strip the housing threads.

The Safety Screw is a blue colored hex head screw that, when installed, prevents the operator from accessing the non-eye safe HI PWR modes of operation. Unit standing operating procedures will provide direction on removal of the Safety Screw to enable the HI PWR modes of operation. A 3/32 in. Hex Key is used to remove the Safety Screw.

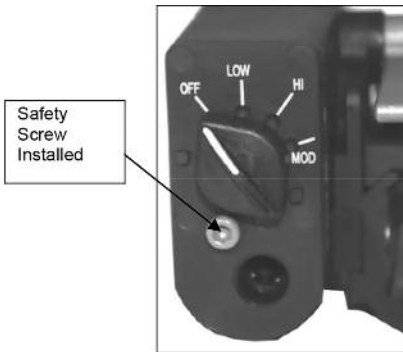

**Figure 3-3 Safety Screw Installed (Shown in Training Mode)**

### 3.2.c Integrated Momentary Activation Switch

The Activation Mode Selector Switch must be turned to Hi or Low to use the Integrated Momentary Activation Switch.

The Integrated Momentary Activation Switch is located on the top of the laser housing just above the word "FIRE". A round textured button marks the switch area.

Firmly pressing and holding the switch activates the laser function selected by the Activation Mode Selector Switch. When the switch is released, the laser turns off.

Pressing the Integrated Momentary Activation Switch twice in rapid succession will activate the laser in a continuous ON mode for 5 minutes.



Integrated  
Momentary  
Activation  
Switch

**Figure 3.4 Integrated Momentary Activation Switch**

Pressing the Integrated Momentary Activation Switch once again at any time during the 5 minute period will return the unit to momentary operation.

### 3.2.d Activation and Low Battery Indicator LED

An LED indicator light is located on the rear housing to the left of the Activation Mode Selector Switch. When lit, it indicates that the laser is actively emitting laser energy.

When the Activation Mode Selector Switch is turned to an operating position, the LED will light up if either the Remote Cable Switch or Integrated Momentary Activation Switch is depressed, indicating that the laser is ON. The LED will remain lit until the Integrated Momentary Activation Switch or Remote Cable Switch is released.

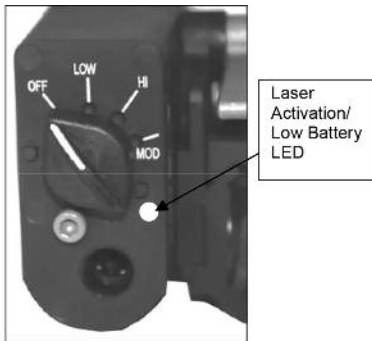

**Figure 3.5 Laser Activation/Low Battery LED**

When the Remote Cable Switch or Integrated Momentary Activation Switch has been depressed twice in rapid succession, the LED will light up indicating that the laser is functioning in a constant ON mode. The LED will remain lit for

5 minutes or until either the Integrated Momentary Activation Switch or Remote Cable Switch is pressed again.

When the LED light blinks, the laser will continue to operate for approximately 20 minutes. This indicates an extremely low battery condition and the battery should be replaced IMMEDIATELY.

### **3.2.f Standard Remote Cable Port**

#### **CAUTION**

DO NOT remove the Remote Cable Switch by pulling on the cable.

#### **NOTE**

The Activation Mode Selector Switch must be turned to Hi or Low to use the Remote Cable Switch.

The Remote Cable Switch plugs into the back of the laser for weapon mounted use. Pressing the Remote Cable Switch activates the laser in the operational mode selected by the Activation Mode Selector Switch. When the remote cable switch is released, the laser turns off. When the Remote Cable Switch is pressed twice in rapid succession the laser will switch to a constant ON mode for 5 minutes or until the Remote Cable Switch is pressed once again to return the unit to momentary activation.

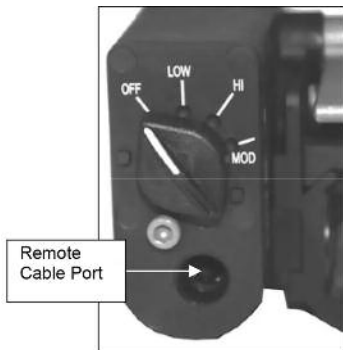

**Figure 3-6 Remote Cable Port**

### **3.2.g Remote Cable Switch**

#### **CAUTION**

DO NOT remove the Remote Cable Switch by pulling on the cable.

#### **NOTE**

The laser Activation Mode Selector Switch must be turned to Hi or Low to use the Remote Cable Switch.

The Remote Cable Switch plugs into the Remote Cable Port as shown in Figure 3-6. When plugged into place, the threaded retainer cap is screwed into the threaded recess surrounding the Remote Cable Port to prevent the Remote Cable Switch from being accidentally pulled loose.

To remove the Remote Cable Switch, turn the threaded retainer cap in a CCW direction until it is loose and pull back on the Remote Cable Plug.

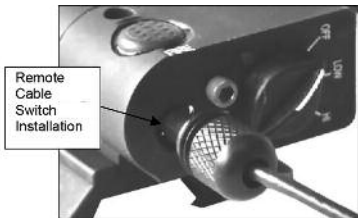

**Figure 3-7 Installation of the Remote Cable Switch**

### 3.2.h Exit Port Cover

#### NOTE

The Exit Port Cover blocks the emission of laser energy being emitted from an operating unit.

The ITAL-A and OTAL-A are supplied with Exit Port Covers.

The Exit Port Cover is held in place by the retention studs located above and below each exit window as shown in Figure 3-8.

Install the Exit Port Cover over the exit port by pulling gently forward until it can be moved into place over the laser Exit Port Lens. Press into place. When the laser is not in use, it should be stored with the Exit Port Cover to protect the lens.

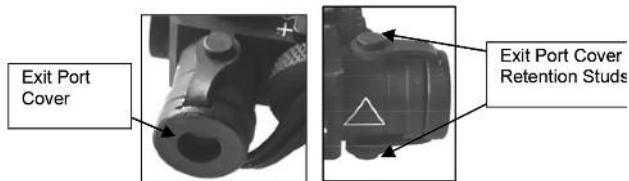

**Figure 3-8 Exit Port Cover Installation**

### 3.2.1 Boresight Adjusters

#### **CAUTION**

DO NOT over adjust the adjusters by forcing them beyond their end of travel.

#### **NOTE**

In extreme cold temperatures the adjusters may offer more resistance.

The adjuster may offer some resistance as you turn it in a CW direction from the factory neutral position. When the adjuster is harder to turn, it has reached the maximum CW travel. ITAL-A and OTAL-A are for use on weapons where the MIL-STD-1913 rail is parallel with the bore of the weapon. In the factory neutral position the laser beam should project on the same side of the target as the laser is mounted and must fall within 15 cm of the bore at 25 meters.

The laser is equipped with boresight adjusters to adjust the laser for elevation and elevation. Move the adjusters using a coin, expended cartridge case or multi-tool. Each adjuster click will move the laser beam approximately 0.5" at 25 meters.

The laser housing is marked adjacent to the adjuster with arrows and the letters D/U and R/L indicating the direction that the laser beam will move on the target, if an adjuster is turned when the laser is mounted in the horizontal (top) position. The adjusters will move the laser beam approximately 10" or 25.4 cm in each direction from the factory neutral preset position at 25 meters.

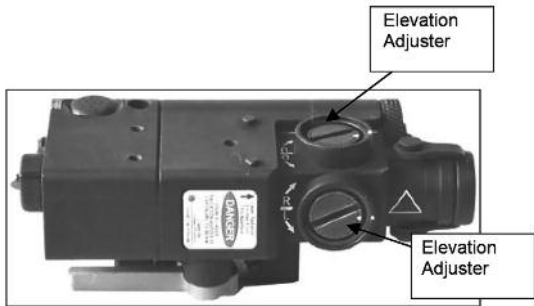

**Figure 3-9 Bore sight Adjusters**

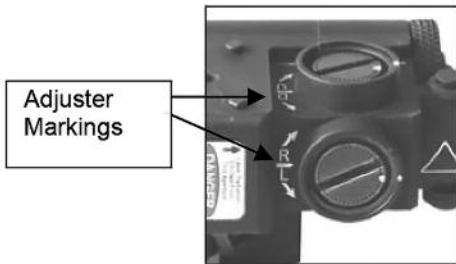

**Figure 3-10 Adjuster Markings on Housing**

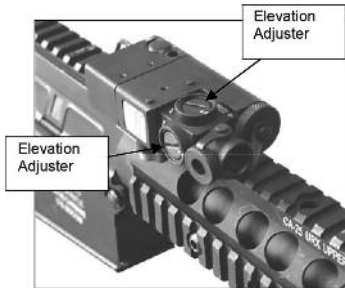

**Figure 3-11 Boresight Adjusters (Top Mounted)**

**Table 3-2 Adjuster Rotation and Shot Group Movement (Top Mounted)**

<b>ZEROING THE LASER BEAM</b>	<b>Adjuster Movement</b>	<b>Shot Group Movement</b>
Top Adjuster Elevation (guard marked D/U)	CW	Up
	CCW	Down
Side Adjuster Elevation (guard marked R/L)	CW	Right
	CCW	Left

When adjusting in a CCW direction, apply a positive load to the adjuster by turning an additional 1/4 turn (12 clicks) CCW, then make the final adjustments by turning the adjusters in a CW direction. No positive load is required when adjustments are made in the CW direction.

## CHAPTER III – SECTION II MOUNTING PROCEDURES

---

### 3.3 MOUNTING PROCEDURES

#### **WARNING**

Be sure the weapon is CLEAR and on SAFE before proceeding.

#### **NOTE**

The Quick Release Mount is intended to conform to both slightly oversized and slightly undersized rails. No tools are required to tighten the mount. If the throw lever arm cannot be easily tightened using fingers, inspect the mounting base to make sure it is properly seated on the rail.

DO NOT force the lever arm down to tighten the Quick Release Mount as it may damage the mount and cause zero retention problems.

The laser may be placed at any position (forward and aft) on the rail that is convenient for the operator. If the laser is removed from the rail, the operator must take note of the position at which it was zeroed, and return it to the same position in order to ensure that zero is retained.

Failure to fully close the Quick Release Mount will cause zero retention problems. Ensure that the base of the Mount is fully seated on the MIL-STD- 1913 rail with NO front or rear overhang.

ITAL-A and OTAL-A are for use on weapons where the MIL-STD-1913 rail is parallel with the bore of the weapon. In the factory neutral position the laser beam should project on the same side of the target as the laser is mounted and must fall within 15 cm of the bore at 25 meters.

The laser is supplied with a Quick Release Mount used to attach the unit to weapons equipped with a MIL-STD-1913 rail. Place the unit far enough back on the rail to allow for battery replacement without removal from the weapon. If removed, the laser must be returned to the same position on the rail to retain zero.

Open the Quick Release Mount so that the lever arm is perpendicular to the housing. Align the cross bar on the base of the mounting bracket with the appropriate slot in the MIL-STD-1913 rail. Seat the mount on the rail and move the lever arm towards the rear of the unit until it is parallel with the housing.

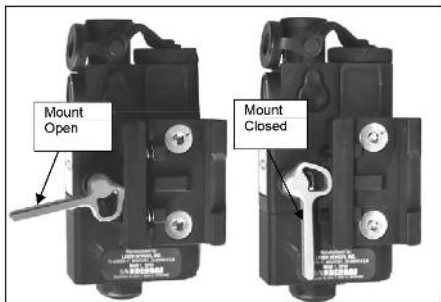

**Figure 3-13 Quick Release Mount Configuration**

## CHAPTER III – SECTION III BORESIGHTING/ZEROING PROCEDURES

---

This section provides boresighting/zeroing instructions for using the AA Laser Borelight, Item No. 9090 on a 25-meter range.

### 3.4 PLACING A POSITIVE LOAD ON THE ADJUSTERS

#### CAUTION

**DO NOT** over-adjust the adjusters by forcing them beyond their end of travel.

#### NOTE

A Positive Load is required anytime an adjustment to the laser beam is made in a CCW direction. A Positive Load is not required when making a CW adjustment. Positive Load is the controlled compression of the spring within the adjuster mechanism to ensure the highest level of accuracy is maintained after the weapon is boresighted or zeroed.

When adjusting in a CCW direction, apply a positive load to the adjuster by turning an additional 1/4 turn (12 clicks) CCW, then make the final boresighting/zeroing adjustments by turning the adjusters in a CW direction. For example, to move the adjuster one (1) click CCW, turn the adjuster CCW twelve (12) clicks and then turn it CW eleven (11) clicks to the new position.

### 3.5 FACTORY NEUTRAL PRESET

## CAUTION

**DO NOT** over-adjust the adjusters by forcing them beyond their end of travel.

## NOTE

The adjuster may offer some resistance as you turn it in a CW direction from the factory neutral position. When the adjuster is harder to turn, it has reached the maximum CW travel.

The laser is preset at the factory to a neutral position. In the neutral position the laser beam is parallel to the bore of the weapon. The laser beam can be returned to the factory alignment (neutral position) using the following procedure:

- Turn the adjuster marked D/U CW to the natural stop.
- Turn it CCW one and one-quarter (1 1/4) turn.
- Turn it CW until the white dot on the adjuster aligns with the white dot on the adjuster guard.
- Turn the adjuster marked R/L CW to the natural stop.
- Turn it CCW one and one-quarter (1 1/4) turn.
- Turn it CW until the white dot on the adjuster aligns with the white dot on the adjuster guard.

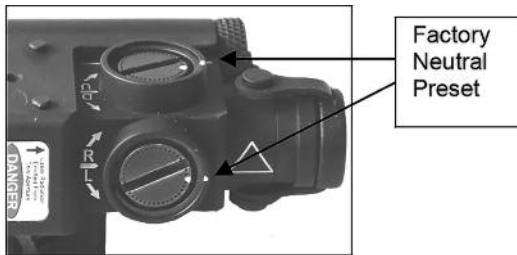

**Figure 3-14 Neutral Preset**

**Table 3-4 Factory Neutral Preset**

**Adjuster**

**Instruction**

Adjuster Guard marked D/U

First, turn CW to end of travel. DO NOT force past mechanical stop. Next, turn CCW 1 1/4 turns. Finally, turn CW to align the dot on the adjuster with the dot on the adjuster guard.

Adjuster Guard marked R/L

### 3.6.a Boresight Using the Double A Borelight

#### **WARNING**

NEVER boresight in the High Power mode of operation.

#### **CAUTION**

**DO NOT** over-adjust the adjusters by forcing them beyond their end of travel.

#### **NOTE**

ALWAYS boresight/zero the laser starting with the Adjuster marked U/D.

Always move the adjusters slowly, one click at a time, to prevent the adjuster from jumping detents.

In extreme cold temperatures, the adjusters may offer more resistance.

The adjuster may offer some resistance as you turn it in a CW direction from the factory neutral position. When the adjuster is harder to turn it has reached the maximum CW travel.

A positive load is required on the adjustment mechanism when boresighting/zeroing the laser in order to retail the set alignment. See Section 3.4.

ITAL-A and OTAL-A are for use on weapons where the MIL-STD- 1913 rail is parallel with the bore of the weapon. In the factory neutral position the laser beam

should project on the same side of the target as the laser is mounted and must fall within 15 cm of the bore at 25 meters. See Section 3.5.

This procedure is used to boresight the laser on its weapon for a distance of 300, 400 or 500 meters using the Double A Borelight System, Item No. 9090.

Refer to the Borelight Operator's Manual for instructions on creating boresight targets. Each adjuster click moves the strike point by approximately 4mm on the 10-meter boresight offset target.

1. Create the 10-Meter Boresight Target for the weapon combination for which boresighting is required using the 10-Meter Boresight Target Offsets in Table 3-4.
2. Position the target at 10 meters oriented in a level vertical position. Proper positioning of the target is critical for accurate boresighting results.
3. Stabilize the weapon so it does not move and insert the appropriate Borelight assembly into the muzzle of the weapon.
4. Rotate the Mode Selector Switch to the LOW position and verify that the Borelight is properly aligned. Refer to the Borelight Operator's Manual for boresighting procedures.
5. Adjust the target as required to place the laser dot on the target location marked "Laser Borelight."

6. Activate the aiming laser and adjust the D/U Aiming Laser windage and elevation adjusters until the point is centered on the corresponding offset location.
7. A positive load is required on the adjustment mechanism when boresighting/zeroing the laser in order to retain the set alignment. See Section 3.4.
8. The weapon combination is now boresighted. Rotate the Laser Activation Mode Selector Switch and the Borelight activation switch to OFF and remove the Borelight from the weapon.

### **3.6.b Zeroing on a 25-Meter Range**

#### **CAUTION**

**DO NOT** over-adjust the adjusters by forcing them beyond their end of travel.

#### **NOTE**

ALWAYS boresight/zero the laser starting with the Adjuster marked U/D. Always move the adjusters slowly, one click at a time, to prevent the adjuster from jumping detents.

In extreme cold temperatures the adjusters may offer more resistance. The adjuster may offer some resistance as you turn it in a CW direction from the factory neutral position. When the adjuster is harder to turn it has reached the maximum CW travel.

A positive load is required on the adjustment mechanism when boresighting/zeroing the laser in order to retail the set alignment. See Section 3.4. ITAL-A and OTAL-A is for use on weapons where the MIL-STD- 1913 rail is parallel with the bore of the weapon. In the factory neutral position the laser beam should project on the same side of the target as the laser is mounted and must fall within 15 cm of the bore at 25 meters. See Section 3.5.

Refer to Table 3-3 for adjuster rotation and direction of shot group movement. Each adjuster click moves the strike point by approximately 1/2 square (0.5 cm) on the M16A2/M16A4 25 meter zeroing target.

1. On a 25-meter zeroing target, mark the designated strike point and designated 4 cm/6 cm strike zone based on the weapon you are using.
2. Mount the target on an "E" silhouette or other suitable surface at 25 meters.
3. Cut a 3 cm square from the center of the target.

4. Set the laser adjusters to their factory neutral position as described in Section 3.5.
5. Activate the laser by rotating the Activation Mode Selector Switch to Low. Press the Integrated Momentary Activation Switch or the Remote Cable Switch twice in rapid succession to activate the laser continuously. Aim center mass of the target until the aiming laser disappears through the 3 cm cut out.
6. Fire a 3-round shot group and note the center of the shot group relative to the designated strike zone.
7. Adjust the aiming beam adjusters to move the center of the shot group to the designated strike zone, applying a positive load to the adjusters. See Section 3.4.
8. Repeat steps 6 and 7 until the shot group falls within the strike zone.
9. When firing the M16, M4 series or M240 series of weapons, when 5 out of 6 consecutive rounds are in the designated 4 cm strike zone, you are zeroed. When firing the M249 series of weapons, when 5 out of 12 non-consecutive rounds are within a 6 cm square, the weapon is zeroed. Rotate the laser Activation Mode Selector Switch to OFF.

## **CHAPTER IV – SECTION I PREVENTIVE MAINTENANCE CHECKS**

---

### **NOTE**

Table 4-1 Preventive Maintenance Checks, has been provided so that you can keep your equipment in good operating condition.

Perform functional tests in the order listed in Table 4-1. Operating Procedures are detailed in Chapter III, Section I.

The Safety Screw must be installed in the Training Position. See Paragraph 3.2.c for Safety Screw operation.

Functional testing of the laser to ensure proper operation should be performed in a dark room or area away from light.

### **4.1.a Warnings and Cautions**

Always observe the WARNINGS and CAUTIONS appearing in the table.

## **4.1.b Explanation of Table Entries**

### **1. Item Number**

Numbers in this column are for reference. Item numbers also appear in the order that you must perform the checks and services listed.

### **2. Interval**

This column tells you when you must do the procedure in the procedure column. BEFORE (B) PROCEDURES must be done before you operate or use the equipment. DURING (D) PROCEDURES must be done during the time you are operating or using the equipment. AFTER (A) PROCEDURES must be done immediately after you have operated or used the equipment.

### **3. Item to Check/Service**

This column provides the item to be checked or serviced.

### **4. Procedure**

This column gives the procedure you must do to check the item.

### **5. Not Fully Mission Capable If**

Information in this column tells you what faults will keep your equipment from being capable of performing its primary mission.

Be sure to observe all special information and notes that appear in your table.

**Table 4-1 Preventive Maintenance Checks and Services**

<b>Item No.</b>	<b>Interval</b>	<b>Item to Check/Service</b>	<b>Procedure</b>	<b>Not Fully Mission Capable If:</b>
1	B/D/A	Laser Exterior	-Check housing for separation between the front and the rear section of the housing, missing screws and missing switch knob, windage and elevation adjuster.	A gap appears between the front and the rear section of the housing, missing switch knob, or adjuster cover.
2	B/A	Exit Port Covers	-Check for broken or missing covers, exit port cover retention studs. -Move the Exit Port Covers to the open position.	
3	B/A	Exit Port Lens	-Check for cracked, dirty or broken lenses.	If cracked or missing lens.
4	B/A	Adjusters	-Check for broken, missing or stripped Adjusters.	Adjusters broken, missing or stripped or laser fails to move.

**Table 4-1 Preventive Maintenance Checks and Services**

<b>Item No.</b>	<b>Interval</b>	<b>Item to Check/Service</b>	<b>Procedure</b>	<b>Not Fully Mission Capable If:</b>
5	B/D/A	Quick Release Mount	-Check attachment to housing, broken, missing parts. -Inspect crossbar and mount base for dirt and corrosion. -If laser is loose on the rail: Move to a different position on the rail; Move to a different rail on weapon; Replace the rail on weapon.	Throw lever or Standard Rail Grabber mount is loose, missing parts or broke.
6	B/D/A	Safety Screw	-Broken or Missing.	Broken or Missing.
7	B/D/A	Remote Cable Port	-Check for mud or dirt and clean as needed.	
8	B/A	Battery Compartment	-Check for corrosion, presence of O-ring, spring, battery cap lanyard. Inspect threads for dirt or damage.	Corroded or broken contacts.
9	B/A	Battery Compartment O-Ring	-Check O-ring for cuts, cracks. -Lubricate as needed.	

**Table 4-1 Preventive Maintenance Checks and Services**

<b>Item No.</b>	<b>Interval</b>	<b>Item to Check/Service</b>	<b>Procedure</b>	<b>Not Fully Mission Capable If:</b>
10	B/A	Install DL-123A Battery	-Install a known good battery	
11	B/A	Activation Mode Selector Switch and Integrated Momentary Activation Switch	-Select LOW power. -Use the Integrated Momentary Activation Switch and observe the beam spot on wall. -Select HIGH power and repeat the activation. -Use of a NVD is required to view the IR beam.	Activation Mode Selector Switch inoperative with the laser beam is not visible.
12	B	Boresight Alignment	-Confirm that the laser can be boresighted /zeroed on the weapon on which it will be mounted.	Cannot be zeroed or boresighted to the weapon.
13	B/D/A	LED Status Indicator	-Observe green LED is lit when the laser is activated.	If LED is red or orange in color, replace battery.
14	B/A	Remote Cable Switch	-Insert the remote cable switch and activate the laser.	
15	B	Exit Port Covers	-Close exit port covers.	
16	A	Textile Bag	-Check for torn fabric.	
17	A	Battery	-Remove battery.	

## CHAPTER IV – SECTION II TROUBLESHOOTING

### 4.2 GENERAL

The purpose of troubleshooting is to identify the most frequent equipment malfunctions, probable causes, and corrective actions required. Table 4-2 lists the common malfunctions which may be found during the operation or maintenance of the laser and accessory equipment. Perform the tests, inspections and corrective actions in the order listed. This manual cannot list all malfunctions that may occur; or all tests, inspections and corrective actions.

**Table 4-1 Preventive Maintenance Checks and Services**

<b>Malfunction</b>	<b>Test / Inspection</b>	<b>Corrective Action</b>	<b>Ref. Para.</b>
1. Laser beam fails to come on or stay on	a. Ensure Activation Mode Selector Switch is in proper position.	-Properly align switch.	3.2.b
	b. Verify Exit Port Cover is removed and that the Exit Port Lens is not obscured by mud/dirt.	-Remove Exit Port Covers. -Clean POINT/ILLUM . Exit Port Lenses.	4.3.b
	c. Verify battery installation.	-Tighten battery cap. -Install new battery.	3.2.a
	d. Inspect battery cap for damage or corrosion.	-Notify Unit Maintenance.	

**Table 4-1 Preventive Maintenance Checks and Services**

<b>Malfunction</b>	<b>Test / Inspection</b>	<b>Corrective Action</b>	<b>Ref. Para.</b>
1. Laser Beam fail to come on or stay on.	e. Inspect battery contact spring in the battery compartment for damage or corrosion.	-Notify Unit Maintenance.	
	f. Possible internal failure.	-Notify Unit Maintenance.	
2. Laser Beam has become weak (not as bright).	a. Verify Exit Port Cover is removed and that Exit Port Lens is not obscured by mud / dirt.	-Remove Exit Port Cover. -Clean POINT & ILLUM Exit Port Lenses.	4.3.b
	b. Verify proper battery installation.	-Tighten battery cap. -Install new battery.	3.2.a --
	c. Verify Exit Port Lens is not scratched or pitted.	-Notify Unit Maintenance.	
3.Low Battery Indicator Light remains red when new battery is installed.	a. Inspect battery compartment for corrosion.	-Clean battery compartment contacts.	4.3.c
	b. Inspect Battery Cap contact for corrosion.	-Clean battery cap contact.	4.3.d
	c. Inspect battery cap and housing threads for contamination.	-Clean battery cap and housing threads.	4.3.d
4. Laser beam DOES NOT move when adjuster is rotated.	a. Verify adjuster function.	-Clean as required. -Notify Unit Maintenance.	4.3.a

**Table 4-1 Preventive Maintenance Checks and Services**

<b>Malfunction</b>	<b>Test / Inspection</b>	<b>Corrective Action</b>	<b>Ref. Para.</b>
5. Remote Cable Switch inoperable, but Integrated Momentary Activation Switch functions.	a. Verify Remote Cable Switch plug is fully seated.	-Reconnect plug.	3.2.g
	b. Verify Remote Cable Port is free of mud / dirt.	-Flush with water.	4.3.f
	c. Inspect Remote Cable Plug Contacts.	-Clean as needed.	4.3.f
	d. Verify function of Remote Cable Switch.	-Notify Unit Maintenance.	-
6. Laser cannot be zeroed to weapon.	a. Verify Quick Release Mount is properly positioned/secured to weapon.	-Properly position and secure.	3.3
	b. If laser is loose on rail: -Move to different position on rail. -Move to different rail on weapon. -Replace rail on weapon.		-
	c. Inspect mount base for corrosion or dirt.	-Clean as required. -Notify Unit Maintenance.	4.3.a
	d. Verify the laser is properly secured to the mounting bracket.	-Notify Unit Maintenance.	-
	e. Verify mounting bracket is not damaged.	-Notify Unit Maintenance.	-

## **CHAPTER IV – SECTION III OPERATOR MAINTENANCE**

---

### **4.3 GENERAL**

#### **WARNING**

DO NOT store the laser with the battery installed.

#### **CAUTION**

Use ONLY authorized weapons cleaning supplies on the laser or permanent damage may occur.

The ITAL-A and OTAL-A are rugged, compact laser devices that are designed to operate in severe military environments. The exterior housing is made of aircraft grade aluminum and the outer components are made of chemically resistant materials that will not be harmed by chemicals normally encountered during military operations. Operator maintenance is limited to the inspection and cleaning of the external surfaces, replacement of the battery before each mission and removal of the battery after each mission.

### **4.3.a External Cleaning**

Clean the exterior of the laser by flushing with water and wiping with a clean, soft cloth. Cleaning should be done whenever the laser becomes dirty or after exposure to salt water.

### **4.3.b Exit Port Lens Cleaning**

To clean the Exit Port Lenses, wipe clean using a soft cloth or disposable applicator dampened with water.

### **4.3.c Battery Compartment**

Before each use, inspect the battery and battery compartment for dirt, dust, or corrosion. If dirty, clean using a soft cloth or disposable applicator.

### **4.3.d Battery Cap**

Prior to water operations or immersion, inspect the O-ring seals in the battery cap to make sure they are free of sand or dirt particles. If the O-ring becomes cut, nicked or dried out, it should be replaced. If the battery cap is bent or scratched in the O-ring seating area, it should be replaced.

### **4.3.e Battery Removal and Replacement**

Refer to Chapter III, Paragraph 3.2.a for Battery Installation procedures. No special tools or equipment are required to replace the battery.

### **4.3.f Remote Cable Port**

Before each use, inspect the remote cable port for dirt, dust, or corrosion. Thoroughly clean the receptacle by flushing with water, then wipe with a soft cloth or disposable applicator.

### **4.3.g Battery Compartment O-ring**

#### **NOTE**

Never use a sharp or metal object to remove O-rings, as they damage the O-ring or the O-ring groove contact surface.

Before each use, inspect the battery compartment O-ring for nicks, cuts or damage. Lubricate the O-ring as needed using silicone grease as follows:

1. Gently remove the O-ring. Be careful not to stretch the O-ring.
2. Check the O-ring for hair, sand, lint, or other debris and wipe clean as necessary. Be careful not to stretch the O-ring. If the O-ring is cut or cracked it must be removed and replaced with a new O-ring.

3. If possible, wash your hands prior to greasing the O-ring. Lubricate the O-ring using your fingertips and a small amount of silicone grease until there is a thin film covering the complete surface. DO NOT stretch the O-ring.
4. Before replacing the O-ring, visually inspect the groove in the battery compartment cap for hair, sand, lint, or other debris and wipe clean as necessary.
5. Install the O-ring in the groove at the base of the battery compartment cap, making sure that it is seated uniformly, with no twists or loose areas. Be careful not to stretch the O-ring.

## CHAPTER V – SECTION I UNIT TROUBLESHOOTING

---

### 5.1 GENERAL

The purpose of troubleshooting is to identify the most frequent equipment malfunctions, probable causes and corrective actions required. Table 5-1 lists the most common malfunctions that may occur with the laser. Perform the tests, inspections and corrective actions in the order they are listed. This manual cannot list all malfunctions that may occur; or all tests, inspections and corrective actions. If a malfunction is not listed or is not corrected by corrective actions listed, turn in the entire system.

**Table 5-1 Unit Troubleshooting**

<b>Malfunction</b>	<b>Test / Inspection</b>	<b>Corrective Action</b>	<b>Ref. Para.</b>
1. Laser fail to come on or stay on.	a. Inspect battery compartment for corrosion.	-Clean battery compartment.	5.2.c
	b. Inspect battery cap contact for corrosion.	-Clean battery cap contact.	5.2.d
	c. Inspect battery cap and housing threads for contamination.	-Clean battery cap and housing threads.	5.2.d
	d. Possible internal failure.	-Replace battery cap -Return for repair.	5.7 5.2.b
2. Laser beams have become weak (not as bright).	a. Verify Exit Port Lens is not obscured by dirt.	-Remove Exit Port Cover.	3.2.a
	b. Verify battery installation.	-Clean Exit Port Lenses. -Tighten battery cap. -Install new battery.	
	c. Verify Exit Port Lens is not scratched or pitted.	-Replace battery cap. -Return for repair.	
3. Low Battery Indicator Light remains on when new battery is installed.	a. Inspect battery compartment for corrosion.	-Clean battery compartment contacts.	5.2.c
	b. Inspect Battery Cap contact for corrosion.	-Clean battery cap contact.	5.2.d
	c. Inspect battery cap and housing threads for contamination.	-Clean battery cap and housing threads. -Replace battery cap -Return for repair.	5.2.e

**Table 5-1 Unit Troubleshooting**

<b>Malfunction</b>	<b>Test / Inspection</b>	<b>Corrective Action</b>	<b>Ref. Para.</b>
4. Laser beams do not move.	a. Verify adjuster function.	-Clean as required. -Return for repair.	5.2.a 5.7
5. Remote Cable Switch inoperable, but the Integrated Momentary Activation Switch functions.	a. Inspect Remote Cable Port for dirt or debris.	-Clean remote cable port	5.2.f
	b. Inspect remote cable plug for damaged contacts.	-Replace remote cable assembly.	5.2.g
	c. Possible remote cable failure.	-Replace remote cable -Return for repair.	5.2.g 5.7
6. Laser cannot be aligned, moves on rail, or when reset to factory neutral fails to project the laser beam inline and above the bore at 25 meters.	a. Inspect weapon system rail.	-Refer to appropriate weapons TM.	

## CHAPTER V – SECTION II UNIT MAINTENANCE

---

### 5.2 GENERAL

#### CAUTION

Use ONLY authorized weapons cleaning supplies on the laser or permanent damage may occur.

Unit Maintenance Procedures consist of operational tests, inspections, troubleshooting and the replacement of a limited number of parts (paragraphs 5.2.a through 5.2.g). All authorized repair parts can be installed at the unit level. A laser failing to meet the tests and inspections should be replaced.

#### 5.2.a External Cleaning

Clean the exterior of the laser by flushing with water and wiping with a clean, soft cloth. Cleaning should be done whenever the laser becomes dirty or after exposure to salt water.

#### 5.2.b Exit Port Lens Cleaning

Use a lens cleaning kit to clean the Exit Port lenses.

#### 5.2.c Battery Compartment

Before each use, inspect the battery and battery compartment for dirt, dust or corrosion. Clean the battery compartment by wiping with a soft, clean cloth. If a

damp cloth is used to clean the battery compartment make sure to allow the compartment to air dry completely before reinstalling the battery cap.

#### **5.2.d Battery Cap**

Prior to water operations or immersion, inspect the O-ring and the battery cap to make sure they are free of dirt, moisture or corrosion. Thoroughly clean the O-rings, battery cap and back of the battery compartment that seals against the O-ring using Isopropyl Alcohol. After cleaning, or if the O-ring becomes dried out, lubricate the O-ring using silicone grease. If the O-ring becomes cut or nicked, it should be replaced.

#### **5.2.e Battery Compartment and Housing Threads**

Inspect threading on the battery cap and housing for contamination. If the threading appears to be oily or dirty, clean with Isopropyl Alcohol using a soft, clean cloth.

#### **5.2.f Remote Cable Receptacle**

Before each use, inspect the remote cable receptacle for dirt, dust or corrosion. Thoroughly clean the receptacle, flushing with water and wiping with a soft cloth or disposable applicator.

#### **5.2.g Replace Remote Cable**

See Chapter III, Paragraph 3.2.g for replacement of the Remote Cable Switch.

## 5.3 TESTS AND INSPECTIONS

See Preventive Maintenance Checks and Services Table 4-1.

## 5.4 REMOVAL AND REPLACEMENT OF PARTS

Unit Maintenance is authorized for the removal and replacement of a limited number of assemblies. All repair parts can be installed at the unit level. Special tools or equipment are not required for maintaining the laser.

**The following items are authorized for repair or replacement by Unit Maintenance:**

### 5.4.a Battery Removal and Installation

See Chapter III, Paragraph 3.2.a for procedures.

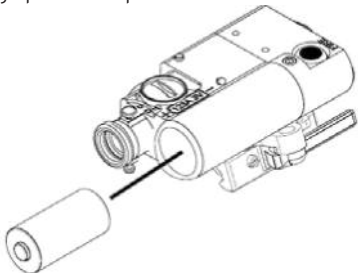

**Figure 5-1 Battery Removal and Installation**

## 5.4.b Remove and Replace Battery Cap

### NOTE

To remove the Battery Cap Retaining Strap it is necessary to remove the Exit Port Cover Retaining Strap first.

Install the Battery Cap Retaining Strap below the Exit Port Cover Retaining Strap under the Laser Exit Port Lens. If necessary, remove the bottom Exit Port Cover strap from the Laser Exit Port Cover then install the Battery Cap Retaining Strap.

To remove, stretch the end of the Retaining Strap over the stud on the Battery Cap then stretch the other end over the stud located under the Laser Exit Port Lens.

To install, stretch the end of the retaining strap over the stud located on the battery cap.

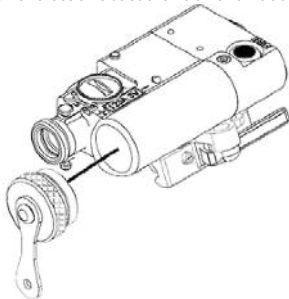

**Figure 5-2 Remove and Replace Battery Cap**

### 5.4.c Removal and Replacement of Battery Cap Retaining Strap

#### NOTE

Install the Battery Cap Retaining Strap below the Exit Port Cover Retaining Strap used located under the Laser Exit Port Lens. If necessary, remove the bottom Exit Port Cover strap from the Laser Exit Port Cover then install the Battery Cap Retaining Strap.

To remove the Battery Cap Retaining Strap it is necessary to remove the Exit Port Cover Retaining Strap first.

To install, stretch the end of the retaining strap over the stud located on the battery cap. Stretch the other end of the retaining strap over the stud located directly below the Laser Exit Port Lens.

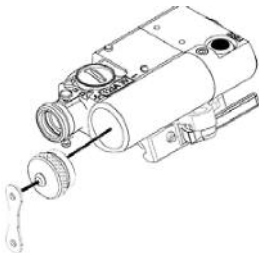

**Figure 5-3 Remove and Replace Battery Cap Retaining Strap**

To remove, stretch the end of the Retaining Strap over the stud on the Battery Cap then stretch the other end over the stud located directly below the Laser Exit Port Lens

#### 5.4.d Remove and Replace Battery Cap O-ring

##### NOTE

NEVER use a sharp or metal object to remove O-rings as they may damage the O-ring or the O-ring groove contact surface.

Inspect the O-ring for nicks, cracks, cuts or abrasion. Also check to make sure that it feels soft. If damaged, replace the O-ring.

To remove pull the O-ring out of the groove at the base of the threaded portion of the battery cap and remove. Install the new O-ring by pulling it onto the battery cap so that it fits in the groove located at the base of the threaded portion of the battery cap.

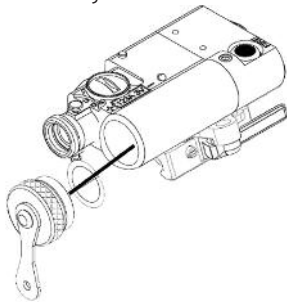

**Figure 5-4 Remove and Replace Battery Cap O-ring**

## 5.4.e Remove and Replace Safety Screw

### WARNING

In order to make the laser operate in the High Power modes of operation the blue Safety Screw must be removed from the back of the unit. The Armorer will remove and store the Safety Screw.

### CAUTION

DO NOT over tighten the Safety Screw as it may strip the threads in the housing.

The Armorer will remove and store the Safety Screw using a 3/32 in. hex key. The Armorer will install the Safety Screw using a 3/32 in. hex key.

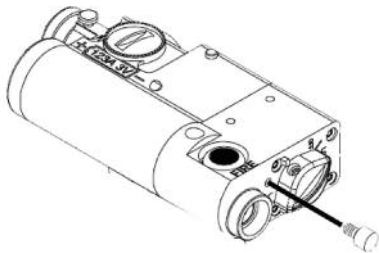
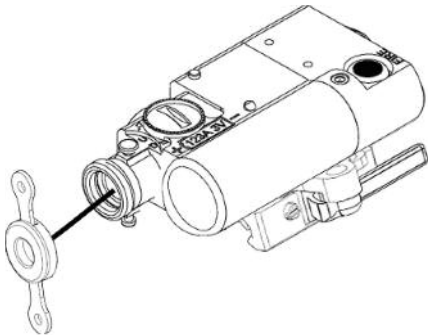

**Figure 5-5 Remove and Replace Safety Screw**

#### 5.4.f Removal and Replacement of Exit Port Cover Retaining Straps

To remove the top Exit Port Cover, pull on the loose end of the Exit Port Cover retaining strap and stretch it over the top stud. Repeat the procedure to remove the bottom Exit Port Cover retaining strap from the laser.

To replace the Exit Port Cover Retaining Straps, stretch the end of the retaining strap over the retaining stud located on the bottom of the housing. Repeat the procedure by stretching the loose end of the retaining strap over the stud located on the top of the housing.



**Figure 5-6 Remove and Replace Exit Port Cover Retaining Straps**

# CHAPTER V – SERVICE/PACKING AND UNPACKING

---

## 5.1 Steiner 3-Year Laser Device Warranty

On all laser devices, Steiner offers a 3-Year Limited Warranty from the date of purchase that covers all laser, optical and electronic components, materials and workmanship. All warranties are void if the serial number or manufacturer's labels affixed to the product have been removed, or if products have been abused, misused, modified, neglected or have been disassembled prior to return to the manufacturer.

## 5.2 Warranty or Repair Service

**5.2.a** If you require warranty or repair service please contact Steiner Optik, and we will determine the best way to fix your device. For more information, email [laserlightsinfo@steiner-optics.com](mailto:laserlightsinfo@steiner-optics.com) or call 888-288-7747.

**5.2.b** To assist the Customer Service with determining if the item is repairable, please provide the following information:

1. Serial Number of the defective item
2. Thorough description of the malfunction, defect or damage
3. An explanation as to how the malfunction, defect or damage occurred, if known.

If Steiner determines that the item is under warranty or should be returned for repair, a Return Material Authorization (RMA) number will be provided.

**5.2.c** When returning the OTAL-A/ITAL-A for service or repair, the following procedures should be followed to prevent any additional damage:

1. Be sure that the OTAL-A/ITAL-A is free of all contaminants such as dirt or any other foreign material.
2. Remove the battery.
3. Place the OTAL-A/ITAL-A in the Shipping Case or Carrying Case if available. If the Shipping Case is not available, individually package each OTAL-A/ITAL-A unit being returned in a suitable container.

**5.2.d** Place the OTAL-A/ITAL-A and a copy of the test report or detailed description of the failure in a suitable packing/shipping container. Mark the package with the RMA number. Ship by the fastest, traceable, prepaid means to the address provided by Steiner Customer Service.

## APPENDIX A REPAIR PARTS

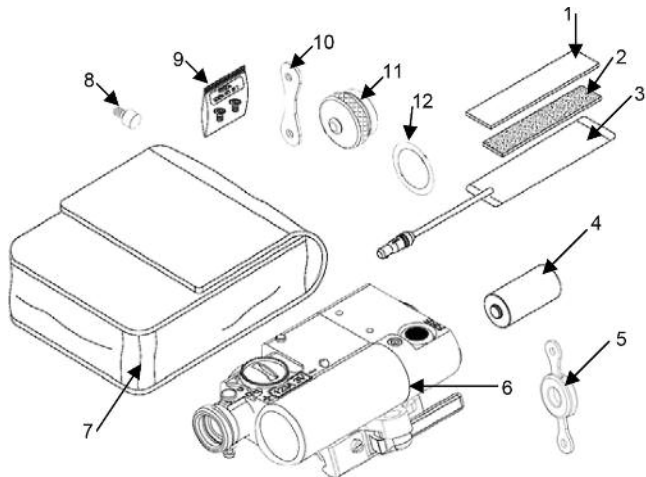

Figure 1 Repair Parts

**Table A-1 Repair Parts List**

<b>Item No.</b>	<b>Description</b>
1	Tape Fastener Loop 5/8" (Black)
2	Tape Fastener Hook 1/2" (Black)
3	Remote Cable Switch, 7"
4	CR 123A Lithium Battery
5	Exit Port Cove
6	ITAL-A or OTAL-A Housing
7	Carrying Case
8	Safety Screw, Hexagon Head
9	Accessory Screws
10	Battery Cap Strap
11	Battery Cap
12	O-ring



STEINER-OPTIK

331 East 8th Street • Greeley, CO 80631

Tel: (888) 228-7747 • Fax: (970) 356-8702

Customer Service: [laserlightsinfo@steiner-optics.com](mailto:laserlightsinfo@steiner-optics.com)

[steiner-optics.com](http://steiner-optics.com)