

SPIR



Technical Manual

SPECIAL PURPOSE INFRARED LED ILLUMINATOR
WEAPON-MOUNTED/HAND-HELD 1,000-METER RANGE

STEINER 
Nothing Escapes You

TABLE OF CONTENTS

	Page
SAFETY SUMMARY	2
HOW TO USE THIS MANUAL	5
CHAPTER I - GENERAL INFORMATION	6
CHAPTER II - EQUIPMENT DESCRIPTION	10
CHAPTER III - OPERATING INSTRUCTIONS.....	16
CHAPTER III - MOUNTING PROCEDURES.....	25
CHAPTER IV - OPERATOR PREVENTIVE MAINTENANCE CHECKS	28
CHAPTER IV - OPERATOR TROUBLESHOOTING.....	32
CHAPTER IV - OPERATOR MAINTENANCE	35
CHAPTER V - SERVICE/PACKING AND UNPACKING	39
REPAIR PARTS	41

SAFETY SUMMARY

This safety summary contains general safety warnings and hazardous materials warnings that must be understood and applied during operation and maintenance of this equipment. Failure to observe these precautions could result in serious injury or death to personnel. Also included are explanations of safety and hazardous materials icons used within this technical manual. The Special Purpose Infrared (SPIR) illuminator is an eye-safe light emitting diode (LED) illuminator.

DEFINITION OF THE FOLLOWING ALERTS THROUGHOUT THIS MANUAL:

WARNING

Identifies a clear danger to the person doing that procedure.

CAUTION

Identifies risk of damage to the equipment.

NOTE

Used to highlight essential procedures, conditions, statements, or convey important instructional data to the user.

WARNING

Be sure the weapon is CLEAR and on SAFE before proceeding.

WARNING RISK OF DETECTION BY ENEMY

To reduce the risk of detection by an enemy using a Night Vision Device (NVD), avoid prolonged activation. The IR beam is more detectable when used in smoke, fog, and rain.

WARNING

DO NOT store the SPIR with the battery installed.

WARNING

Ensure the Activation Mode Selector Switch is in the OFF position before inspecting the Exit Port Lens.

WARNING

If the Activation Selector Switch is not in the OFF position, the SPIR may be inadvertently activated by depressing the FIRE button or Remote Cable Switch.

CAUTION

DO NOT defocus the infrared illuminator by forcing it beyond its normal end of travel.

CAUTION

Prior to submerging, make sure the infrared illuminator focusing knob has been adjusted in a CCW direction to the focus point.

CAUTION

To avoid permanent damage, use ONLY authorized cleaning supplies.

CAUTION

DO NOT remove the Remote Cable Switch by pulling on the cable. Remove by clasping the plug assembly and gently pull.

CAUTION

To prevent damage to the IR LED illuminator Exit Port Cover, open the Exit Port Cover before turning the knob to adjust the focus.

HOW TO USE THIS MANUAL

Usage

You must familiarize yourself with the entire manual before operating the equipment. Read the complete maintenance task before performing maintenance and follow all **WARNINGS, CAUTIONS** and **NOTES**.

Manual Overview

The manual contains sections for Operating and Maintaining the SPIR.

Appendix A Repair Parts

CHAPTER 1—GENERAL INFORMATION

1.1 GENERAL INFORMATION

1.1.a Type of Manual:

Operator and Field Maintenance Manual.

1.1.b Equipment Name:

Special Purpose Infrared Illuminator.

1.1.c Purpose of Equipment:

To illuminate shadowed areas or targets using infrared (IR) LED illuminator for users equipped with a Night Vision Device (NVD).

1.2 REPORTING EQUIPMENT IMPROVEMENT RECOMMENDATIONS

If your equipment needs improvement, let us know. Mail your comments to Steiner Optik, 331 E. 8th, Greeley, CO 80631 or email: laserlightsinfo@steiner-optics.com

1.3 Steiner 3-Year Laser Device Warranty

On all laser devices, Steiner offers a 3-Year Limited Warranty from the date of purchase that covers all laser, optical and electronic components, materials and workmanship. All warranties are void if the serial number or manufacturer's labels affixed to the product have been removed, or if products have been abused, misused, modified, neglected or have been disassembled prior to return to the manufacturer.

1.4 CROSS REFERENCES

Common Name

Battery Cap

Shipping Case

Cotton Swab

Neoprene Jack Plug

O-Ring

Lens Covers

Paddle Switch

Battery

Technical Manual

Tape Fastener Loop

Tape Fastener Hook

Official Name

Battery Box Cover

Textile Bag

Disposable Applicator

Plug Assembly

Gasket

Exit Port Covers

Remote Cable Switch

CR 123A

Operator and Field Maintenance Manual

Fastener, Loop Tape

Fastener, Hook Tape

1.5 LIST OF ABBREVIATIONS

C	Celsius (Centigrade)	mm	Millimeter
CCW	Counter-clockwise	mrاد	Milliradians
cm	Centimeters	mW	Milliwatts
CTA	Common Table of Allowance	nm	Nanometers
CW	Clockwise	No	Number
EA	Each	NOHD	Nominal Ocular Hazard Distance
F	Fahrenheit	NSN	National Stock Number
HI	High	NVD	Night Vision Device
ILLUM	Illuminator	O.D.	Optical Density
in	Inches	OIR	Optical Instrument Reticle
IR	Infrared	Para	Paragraph
LBS	Laser Borelight System	PWR	Power
LED	Light Emitting Diode	QTY	Quantity
LO	Low	RAS	Rail Adapter System
m	Meter	RMA	Return Material Authorization
Max	Maximum	SR	Service Representative
Mfr	Manufacturer	TM	Technical Manual
Min	Minimum	VIS	Visible
MOM	Momentary		

CHAPTER 2 – EQUIPMENT DESCRIPTION

2.1 SYSTEM DESCRIPTION

The SPIR is a Class I device that features infrared (IR) light emitting diode (LED) illuminator for use with a NVD. The modes of operation include: Off, HI - high power, and LOW - low power. Figure 2-1 identifies the distinguishing parts of the SPIR. Table 2-1 and Table 2-2 provide performance specifications.

The IR LED illuminator is equipped with an adjustable bezel to vary the size of the illumination beam based on the size of the target and distance to the target.

The SPIR may be weapon mounted (using the Quick Release Mount) or handheld.

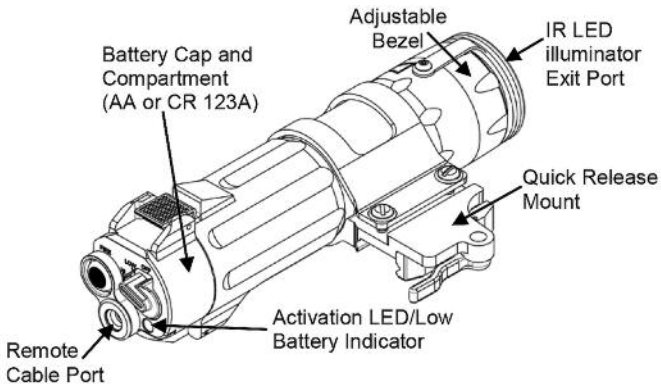

Figure 2-1 SPIR Features

2.2 GENERAL CHARACTERISTICS

Table 2.2 Weight, Dimensions, and Performance

WEIGHT

(with two batteries, CR 123A)	6.5 oz / 184.27 grams
-------------------------------	-----------------------

DIMENSIONS

Length	6.75 in. / 17.14 cm
--------	---------------------

Housing Diameter	1.55 in. / 3.93 cm
------------------	--------------------

Rear Latch Diameter	1.96 in. / 4.98 cm
---------------------	--------------------

Height from Top of Rail	1.80 in. / 4.57 cm
-------------------------	--------------------

PERFORMANCE

Wavelength	850 nm
------------	--------

Output Power	Low - 300 mW
--------------	--------------

	High - 600 mW
--	---------------

Divergence	2° to 30°
------------	-----------

Battery Life (CR 123A)	2 hours
------------------------	---------

IR LED ILLUMINATOR

(STARLIGHT CONDITIONS)

Illuminator (<600 mW)	<900 m
-----------------------	--------

2.3 DESCRIPTION OF MAJOR COMPONENTS

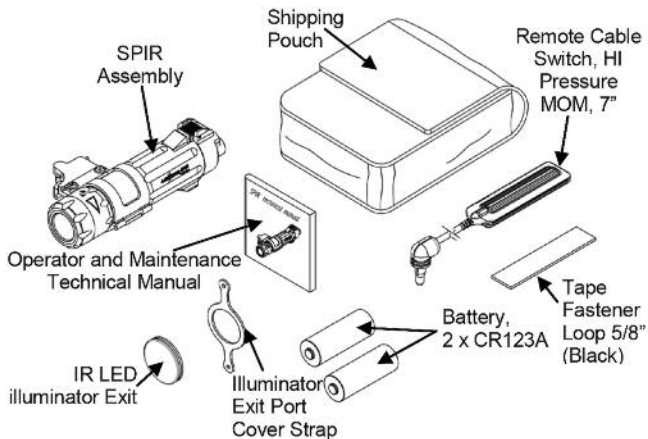

Figure 2-2 Major Components

2.1.b SPIR Assembly

The SPIR device provides an adjustable focus IR LED illuminator. The device is used for aiming, signaling, command and control and for purposes of supplying supplemental IR illumination.

2.1.c Shipping Case

The SPIR is provided with a nylon shipping pouch.

2.1.d Remote Cable Switch

A 7", right angle, Remote Cable Switch activates the SPIR in a momentary (MOM) mode by depressing the pressure pad once.

Pressing the pressure pad twice in rapid succession will activate the device continuously for 5 minutes. Pressing the pressure pad again will return the device to momentary activation. The pressure pad provides a tactile (silent) click that indicates when the switch has been activated.

2.1.e Tape Fastener Loop

The Tape Fastener Loop is provided to secure the Remote Cable Switch to the weapon in a position convenient to the user. The Tape Fastener Hook is pre-attached by the manufacturer to the pressure pad switch and is used to secure the Remote Cable Switch to the weapon in a position convenient to the user.

2.1.f Battery

Two CR 123A (model dependent) batteries are used as a power supply for operating the SPIR. The use of high-quality batteries is recommended to achieve maximum runtime.

2.1.g Operator and Field Maintenance Manual

The Operator and Field Maintenance Manual provide safety information, equipment information, operating instructions, mounting procedures, and maintenance procedures.

NOTE

You must read the entire Operator and Field Maintenance Manual before operating the SPIR and follow all WARNINGS, CAUTIONS and NOTES.

2.1.h Illuminator Exit Port Cover and Strap

The Exit Port Cover strap attaches the Exit Port cover to the SPIR assembly to prevent IR energy emission and protects the lens.

CHAPTER III – SECTION I OPERATING INSTRUCTIONS

WARNING

IR LED ILLUMINATOR

WAVELENGTH: 850 nm

OUTPUT: <600 mW

- DO NOT stare into the laser beam.
- DO NOT look into the laser beam through binoculars or telescopes.
- DO NOT point the laser beam at mirror-like surfaces.
- DO NOT shine the laser beam into other individual's eyes.



3.2 SPIR CONTROLS AND INDICATORS

This section contains a description of the controls and adjustments for the SPIR.

3.2.a Battery Installation

WARNING

DO NOT store the SPIR with the battery installed.

To install, remove, and replace batteries, unclasp the battery cap by pressing on the top of the clasp. Remove and properly discard the spent battery. Inspect the battery compartment for dirt, moisture and corrosion. Clean the battery compartment as needed (refer to Paragraph 4.3.c). Install the battery as indicated by the marking on the SPIR housing (see Figure 3-1). Close and clasp the battery cap.

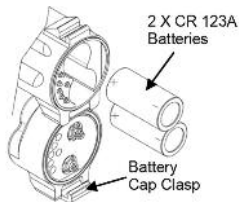

Figure 3-1 Battery Installation CR123A Version

3.2.b Activation Mode Selector Switch

NOTE

The SPIR will not operate if the rotary switch is not precisely aligned with the marked switch position.

In extreme cold temperatures the switch may offer more resistance.

The Activation Mode Selector Switch is located on the right rear of the SPIR housing (see Figure 3-2). The switch is used to select between the various modes of operation. The Activation Mode Selector Switch has three (3) positions. See Table 3-1.

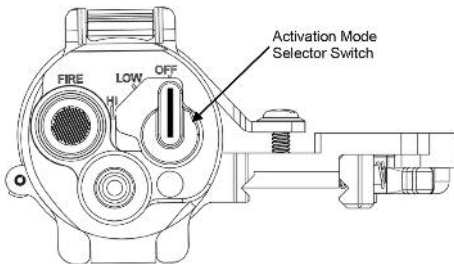

Figure 3-2 Activation Mode Selector Switch

Table 3-1 Activation Mode Selector Switch Functions

Switch Position	Activation Method	Use
OFF	OFF	Not in use or in storage.
LOW	Low is activated when the Remote Cable Switch or FIRE button switch is depressed	Used to illuminate the target area.
HI	High is activated when the Remote Cable Switch or FIRE button switch is depressed	Used to illuminate the target area or shadowed areas.

3.2.c Integrated Momentary Activation Switch

The Integrated Momentary Activation Switch is located on the left rear of the SPIR housing below the word FIRE (see Figure 3-3). Firmly pressing and holding the switch activates the SPIR. When the switch is released, the SPIR turns off.

NOTE

Click sound is minimized by depressing the center of the switch.

Pressing the Integrated Momentary Activation Switch twice in rapid succession will activate the SPIR in a continuous ON mode for 5 minutes. Pressing the Integrated Momentary Activation Switch once again will return the device to the momentary mode.

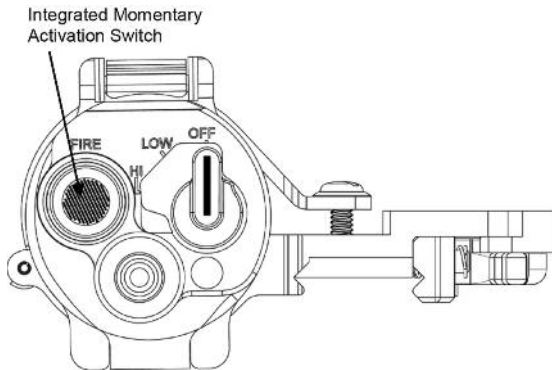

Figure 3-3 Integrated Momentary Activation Switch

3.2.d Low Battery Indicator

A green LED is located on the rear housing at the bottom right of the Activation Mode Selector Switch (see Figure 3-4). When blinking, the LED is a Low Battery Indicator.

When the LED indicator light blinks, it signifies a low battery condition. The batteries should be replaced as soon as possible.

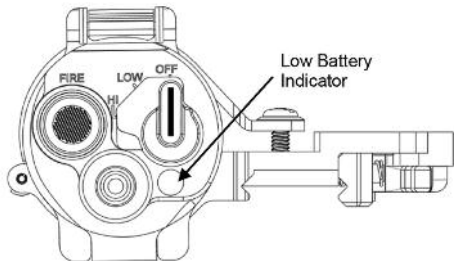

Figure 3-4 Activation LED/Low Battery Indicator

3.2.e Remote Cable Switch

CAUTION

DO NOT remove the Remote Cable Switch by pulling on the cable.

NOTE

When installing the Remote Cable Switch, gently twist the plug into the remote cable port.

The SPIR Activation Mode Selector Switch must be turned to a setting in order to use the Remote Cable Switch.

SPIR will not operate if the rotary switches are not precisely aligned with the marked switch position.

The Remote Cable Switch plugs into the back of the SPIR (see Figure 3-5). Depressing the Remote Cable Switch activates the SPIR in the mode selected by the Activation Mode Selector Switch. When the remote cable switch is released, the SPIR turns off.

In the Momentary Mode when the Remote Cable Switch has been pressed twice in rapid succession, SPIR will activate in a constant ON mode for 5 minutes unless the Remote Cable Switch is pressed once again to return the device to momentary activation.

When the Remote Cable Switch is installed into the SPIR, it automatically locks in place. To remove it, pull back on the plug's sleeve.

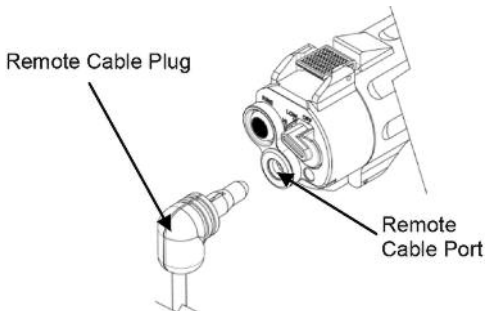

Figure 3-5 Installation of the Remote Cable Switch

3.2.f Exit Port Covers

The SPIR is supplied with an IR LED illuminator Exit Port Cover as shown in Figure 3-6. The Exit Port Cover prevents energy emission when properly installed. The Exit Port Cover is held in place by the retention studs located above and below the exit window.

Install the Exit Port Cover over the illuminator exit port by gently pulling it forward until it may be moved into place over the Exit Port Lens. Align the step on the inside surface of the Exit Port cover with the exit port and press the cover firmly into place. When the SPIR is not in use, store it with the Exit Port Cover in place to protect the Exit Port lens.

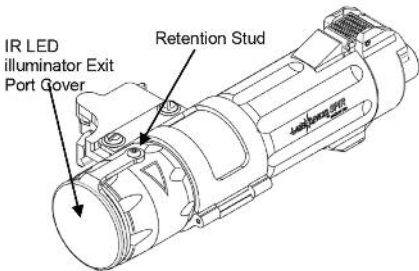

Figure 3-6 Exit Port Cover Installation

3.2.g IR LED illuminator Adjustable Bezel

CAUTION

To prevent damage to the IR LED illuminator Exit Port Cover, open the Exit Port Cover before turning the knob to adjust the focus.

NOTE

In extreme cold temperatures the IR LED illuminator focusing knob may offer more resistance.

The IR LED illuminator focus knob direction of rotation and the corresponding beam size (spot to flood) is indicated by the triangle on the SPIR housing, refer to Figure 3-7.

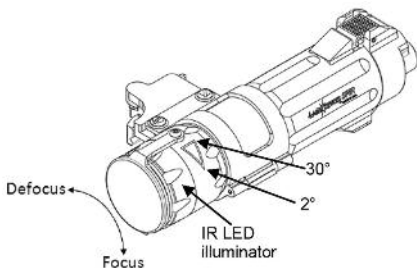

Figure 3-7 The IR LED illuminator Focusing Knob

CHAPTER III – SECTION II MOUNTING PROCEDURES

3.3 MOUNTING PROCEDURES

A Quick Release Mount is used to attach the SPIR to weapons equipped with a MIL-STD-1913 rail. Refer to Figure 3-8 to assemble.

WARNING

Be sure the weapon is CLEAR and on SAFE before proceeding.

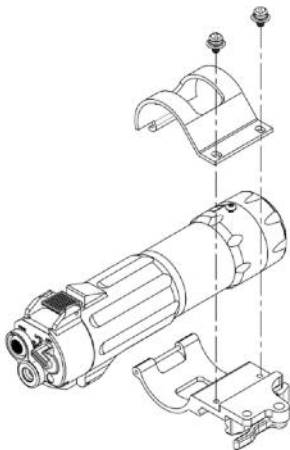

Figure 3-8 Quick Release Mount Attachment

NOTE

The SPIR may be placed at any position (forward and aft) on the rail that is convenient for the user.

When attaching the mount to the SPIR, orient unit in the mount to facilitate battery changes when the SPIR is mounted to the weapon.

The SPIR may be mounted on the LEFT or RIGHT rail using the Quick Release Mount.

Open the Quick Release Mount lever so that it is perpendicular to the SPIR housing.

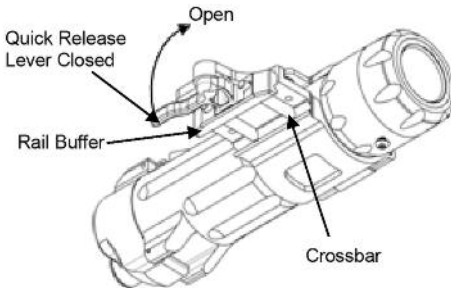

Figure 3-9 Quick Release Mount Configuration

Place the rail buffer against the right side of the MIL-STD-1913 rail and align the crossbar on the bottom of the mount with a slot on the rail. Push forward on the SPIR so that the crossbar contacts the front of the slot on the MIL-STD-1913 rail. Move the Quick Release Lever arm so that it is parallel with the body of the housing. See Figure 3-9. Figure 3-10 shows the SPIR mounted on the top of a weapon.

Install the Remote Cable Switch in a convenient location.

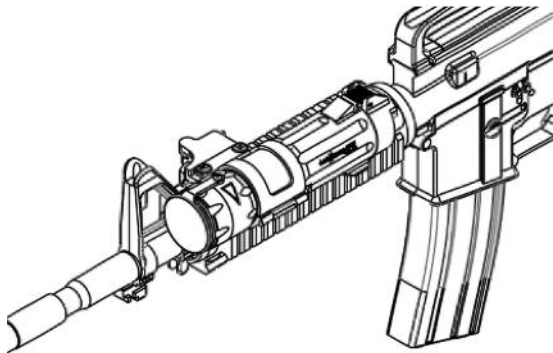

Figure 3-10 Top Mounted

CHAPTER IV – SECTION I PREVENTIVE MAINTENANCE CHECKS

4.1 GENERAL

Table 4-1 Preventive Maintenance Checks, has been provided so that you may keep your equipment in good operating condition.

NOTE

Perform functional tests in the order listed in Table 4-1. Operating Procedures are detailed in Chapter III, Section I.

Functional testing of the SPIR to ensure proper operation should be performed in a dark room or area away from light. Viewing of IR beam must be performed with a NVD, (AN/PVS-7 or AN/PVS-14).

4.1.a Warnings and Cautions

Always observe the WARNINGS and CAUTIONS appearing in the table.

4.1.b Explanation of Table Entries

1. Item Number

Numbers in this column are for reference. Item numbers also appear in the order that you must perform the checks and services listed.

2. Interval

This column tells you when you must do the procedure in the procedure

column. BEFORE (B) PROCEDURES must be done before you operate or use the equipment. DURING (D) PROCEDURES must be done during the time you are operating or using the equipment. AFTER (A) PROCEDURES must be done immediately after you have operated or used the equipment.

3. Item to Check/Service

This column provides the item to be checked or serviced.

4. Procedure

This column gives the procedure you must do to check the item.

5. Not Fully Mission Capable If

Information in this column tells you what faults will keep your equipment from being capable of performing its primary mission.

Be sure to observe all special information and notes that appear in your table.

Table 4-1 Preventive Maintenance Checks and Services

Item No.	Interval	Item to Check/Service	Procedure	Not Fully Mission Capable If:
1	B/D/A	Exterior	Check housing for gasket between the front and rear section of the housing, missing screws, and switch knobs.	-Missing gasket or switch knobs.

Table 4-1 Preventive Maintenance Checks and Services

Item No.	Interval	Item to Check/Service	Procedure	Not Fully Mission Capable If:
WARNING: DO NOT STARE DIRECTLY INTO LIGHT BEAM				
2	B/A	Exit Port Cover.	-Check for broken or missing cover, exit port cover retention studs. -Move the Exit Port Cover to the open position.	
3	B/A	Exit Port Lens.	-Check for cracked, dirty or broken lenses or missing illuminator focusing adjustment.	-If lens cracked or missing or missing illuminator focusing knob.
4	B/D/A	Quick Release Mount. (model dependent)	-Check attachment to housing, broken, missing parts. Inspect rail buffer, crossbar and mount base for dirt and corrosion. If the illuminator is loose on the rail, move to a different position on the rail or move to a different rail on weapon, or replace the rail on weapon.	-Quick Release mount is loose, parts are missing or broken.
5	B/D/A	Remote Cable Port.	-Check for mud or dirt and clean as needed.	
6	B/A	Battery Compartment.	-Check for corrosion and for presence of spring.	-Contacts are corroded or broken.

Table 4-1 Preventive Maintenance Checks and Services

Item No.	Interval	Item to Check/Service	Procedure	Not Fully Mission Capable If:
7	B/A	Install Battery	-Install a known good battery.	
8	B/A	Activation Mode Selector Switch and Integrated Momentary Activation Switch.	-Select LOW using the Activation Mode Selector Switch. Select FIRE and observe the beam spot on wall. Repeat for HI activation position.	-Activation Mode Selector Switch inoperative IR LED illuminator beam spot not visible.
9	B	Exit Port Cover.	-Close exit port cover and press into place.	
10	A	Textile Bag.	-Check for torn fabric.	
11	A	Battery.	-Remove battery.	

CHAPTER IV – SECTION II TROUBLESHOOTING

4.2 GENERAL

The purpose of troubleshooting is to systematically search and identify the source of a problem. The most frequent equipment malfunctions, probable causes and corrective actions for the SPIR are listed in Table 4-2. Perform the tests, inspections and corrective actions in the order they are listed. This manual does not list all malfunctions, tests, inspections, or corrective actions that may occur.

Table 4-1 Preventive Maintenance Checks and Services

Malfunction	Test / Inspection	Corrective Action	Ref. Para.
NOTE: SPIR WILL NOT OPERATE IF THE ROTARY SWITCH IS NOT PRECISELY ALIGNED			
1. Illuminator beam fails to come on or stay on.	a. Ensure Activation switch is on and Mode selector switch is in proper position.	-Properly align switch.	0, 3.2.a
	b. Verify Exit Port Cover is removed and that the Exit Port Lens is not obscured by mud/dirt.	-Remove Exit Port Cover. -Clean illuminator. -Exit Port lens.	4.3.b
	c. Verify battery installation.	-Install new battery.	3.2.a
	d. Inspect battery cap for damage or corrosion.	-Notify Unit Maintenance.	5.3.a
	e. Inspect battery contact spring in the battery compartment for damage or corrosion.	-Notify Unit Maintenance.	5.3.a
2. Illuminator Beam has become weak (not as bright).	a. Verify that Exit Port Cover is removed and that the Exit Port Lens is not obscured	-Remove Exit Port Cover. -Clean illuminator Exit Port lens.	4.3.b
	b. Verify Exit Port Lens is not scratched or pitted	-Notify Unit Maintenance.	
	c. Verify battery installation.	-Install new battery.	3.2.a

Table 4-1 Preventive Maintenance Checks and Services

Malfunction	Test / Inspection	Corrective Action	Ref. Para.
3. Low Battery Indicator Light remains on when new battery is installed.	- Inspect battery compartment for corrosion. - Inspect Battery Cap contact for corrosion.	-Clean battery compartment contacts. -Clean battery cap contact.	4.3.c 3.2.a
4. Illuminator beam does NOT move.	- Verify adjuster function.	-Clean as required.	4.3.a
5. Remote Cable Switch inoperable, but Integrated Momentary Activation Switch functions.	- Verify Remote Cable Switch plug is fully seated. - Verify Remote Cable Port is free of mud/dirt. - Inspect Remote Cable Plug contacts. - Verify function of Remote Cable Switch.	-Reconnect plug. -Flush with water. -Clean as needed. -Notify Unit Maintenance.	3.2.e 4.3.f 4.3.f 5.3.a
6. Illuminator knob turns, but beam does not change Verify knob is free of mud and dirt.	- Verify knob is free of mud and dirt.	-Notify Unit Maintenance.	5.3.a

CHAPTER IV – SECTION III OPERATOR MAINTENANCE

4.3 GENERAL

WARNING

DO NOT store the SPIR with the battery installed.

CAUTION

The use of gun cleaning agents that contain perchloroethylene or methylene chloride may permanently damage the SPIR system.

The SPIR is a rugged, compact illuminator device that is designed to operate in severe environments. The exterior housing is made of aircraft grade aluminum and the outer components are made of chemically resistant materials that will not be harmed by chemicals normally encountered. User maintenance is limited to the inspection and cleaning of the SPIR external surfaces, replacement of the battery before each use and removal of the battery after each use.

4.3.a External Cleaning

Clean the exterior of the SPIR by flushing with water and wiping with a clean, soft cloth. Cleaning should be done whenever the SPIR becomes dirty or after exposure to salt water.

4.3.b Exit Port Lens Cleaning

To clean the Exit Port Lens, wipe clean using a soft cloth or disposable applicator dampened with water.

4.3.c Battery Compartment

Before each use, inspect the battery and battery compartment for dirt, dust, or corrosion. If dirty, clean using a soft cloth or disposable applicator.

4.3.d Battery Cap

Inspect the battery cap and housing for contamination. If it appears to be oily or dirty, clean with Isopropyl Alcohol using a soft, clean cloth.

4.3.f Battery Removal and Replacement

Refer to Chapter III, Paragraph 3.2.a for Battery Installation procedures. No special tools or equipment are required to replace the battery.

4.3.f Remote Cable Port

Before each use, inspect the remote cable port for dirt, dust or corrosion. Thoroughly clean the receptacle by flushing with water then wipe with a soft cloth or disposable applicator.

4.4 REMOVAL AND REPLACEMENT OF PARTS

Maintenance is authorized for the removal and replacement of a limited number of assemblies. Special tools or equipment are not required for maintaining the SPIR.

4.4.a Remove and Install Battery

See Chapter III, Paragraph 3.2.a for procedures. Figure 4-1 depicts the removal and installation of the batteries. Type of battery to use is model dependent.

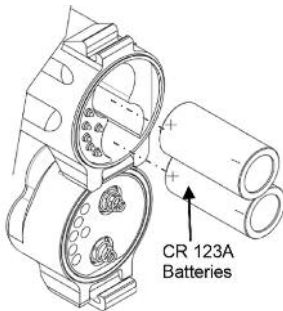

Figure 4-1 Battery Removal and Installation

4.4.b Removal and Replacement of Exit Port Cover Retaining Straps

To remove the top Exit Port Cover, pull on the loose end of the Exit Port Cover retaining strap and stretch it over the top stud. Repeat the procedure to remove the bottom Exit Port Cover retaining strap.

To replace the Exit Port Cover Retaining Straps, stretch the end of the retaining strap over the retaining stud located on the bottom of the housing. Repeat the procedure by stretching the loose end of the retaining strap over the stud located on the top of the housing. Figure 4-2 depicts the removal and replacement of the Exit Port cover and retaining straps.

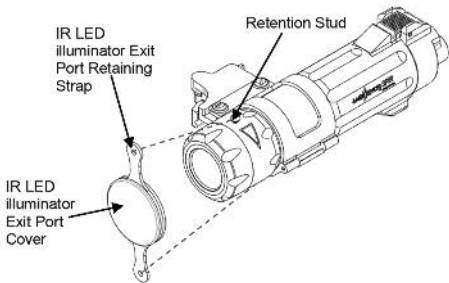

Figure 4-2 Remove and Replace Exit Port Cover Retaining Straps

CHAPTER V – SERVICE/PACKING AND UNPACKING

5.1 Steiner 3-Year Laser Device Warranty

On all laser devices, Steiner offers a 3-Year Limited Warranty from the date of purchase that covers all laser, optical and electronic components, materials and workmanship. All warranties are void if the serial number or manufacturer's labels affixed to the product have been removed, or if products have been abused, misused, modified, neglected or have been disassembled prior to return to the manufacturer.

5.2 Return Instructions

5.2.a If you require warranty or repair service please contact Steiner Optik, and we will determine the best way to fix your device. For more information, email laserlightsinfo@steiner-optics.com or call 888-288-7747.

5.2.b To assist Customer Service with determining if the item is repairable, please provide the following information:

1. Serial Number of the defective item
2. Thorough description of the malfunction, defect or damage
3. An explanation as to how the malfunction, defect or damage occurred, if known.

If the Customer Service determines that the item is under warranty or should be returned for repair, a Return Material Authorization (RMA) number will be provided.

5.2 Return Instructions

5.2.c When returning the SPIR for service or repair, the following procedures should be followed to prevent any additional damage:

1. Be sure that the SPIR is free of all contaminants such as dirt or any other foreign material.
2. Remove the battery.
3. Place the Exit Port Covers over each of the lenses.
4. Place the SPIR in the Shipping Case or Carrying Case if available. If the Shipping Case is not available, individually package each SPIR unit being returned in a suitable container.

5.2.d Place the SPIR and a copy of the test report or detailed description of the failure in a suitable packing/shipping container. Mark the package with the RMA number. Ship by the fastest, traceable, prepaid means to Steiner Optics.

APPENDIX A REPAIR PARTS

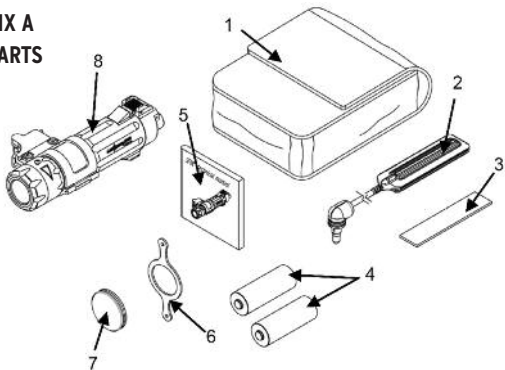

Table A-1 Repair Parts List

Item No.	Description	QTY
1	Bag, Textile Nylon	1
2	Right Angle Remote Cable Switch, 7"	1
3	Loop Tape	1
4	3V Lithium CR 123A Battery	2
5	Technical Manual	1
6/7	IR LED illuminator Dust Cover	1
8	SPIR Assembly	1



STEINER-OPTIK

920 54th Avenue • Suite 200, Greeley, CO 80634

Tel: (888) 228-7747 • Fax: (970) 356-8702

Customer Service: laserlightsinfo@steiner-optics.com

steiner-optics.com